



Count on it.

Parts Catalog

8-Blade EdgeSeries™ Forward Swept Reel DPA Cutting Unit with 7in Reel

Reelmaster® 5010 Series Traction Unit

Model No. 03639—Serial No. 407900000 and Up



Ordering Replacement Parts

To order replacement parts, please supply the part number, the quantity, and the description of each part desired.

Understanding Reference Numbers

Each identified part in an illustration has a reference number. The reference number for a part also appears in the parts list, along with other information about the part.

This catalog uses two special reference number formats, one to indicate parts in a service assembly and another to indicate the quantity of a given part in an illustration.

Service Assembly Reference Numbers

Parts in service assemblies have reference numbers in the form a:b. The a represents the reference number of the entire service assembly and the b represents a sequential number unique to each part within the service assembly.

For example, a wheel assembly might be identified by reference number 6, the tire by 6:1, the valve by 6:2, and the wheel by 6:3. When you order the assembly identified by reference number 6, you receive all parts identified by reference numbers 6:1, 6:2, and 6:3. However, you may also order any part individually. Reference numbers of this type appear in illustration and in parts lists.

Reference Numbers Indicating Quantity

In an illustration, if a reference number indicates more than one part, the reference number has the form nX y. The n represents the quantity of the part, the X is the multiplication symbol, and the y represents the reference number.

For example, in an illustration, the reference number 2X 37 means that two of the parts identified by reference number 37 are indicated.

Contents

Frame Assembly	4
Reel and Bedbar Assembly	5
7in EdgeSeries+ 22in Fairway, 8 Blade, Low Drag, Forward Swept Reel Assembly No. 137-8446	7
Optional 7in EdgeSeries+ 22in Fairway, 5 Blade Radial Reel Assembly No. 137-8444	8
Optional Heavy-Duty MVP Kit No. 120-7230	9
Roller Assembly	10
3 Inch Diameter Long Roller Assembly No. 137-6113	11
Optional 3 Inch Diameter Short Roller Assembly No. 137-6117	12
Plastic Wiehle Roller Assembly No. 114-5400	13
Optional Plastic Shoulder Roller Assembly No. 114-5421	14
Optional Full Front Roller Assembly No. 137-6111	15
Optional High Height-of-Cut Assembly No. 137-0890	16
Shield Assembly	17
Optional Tool Assembly	18
Attachments and Accessories	19

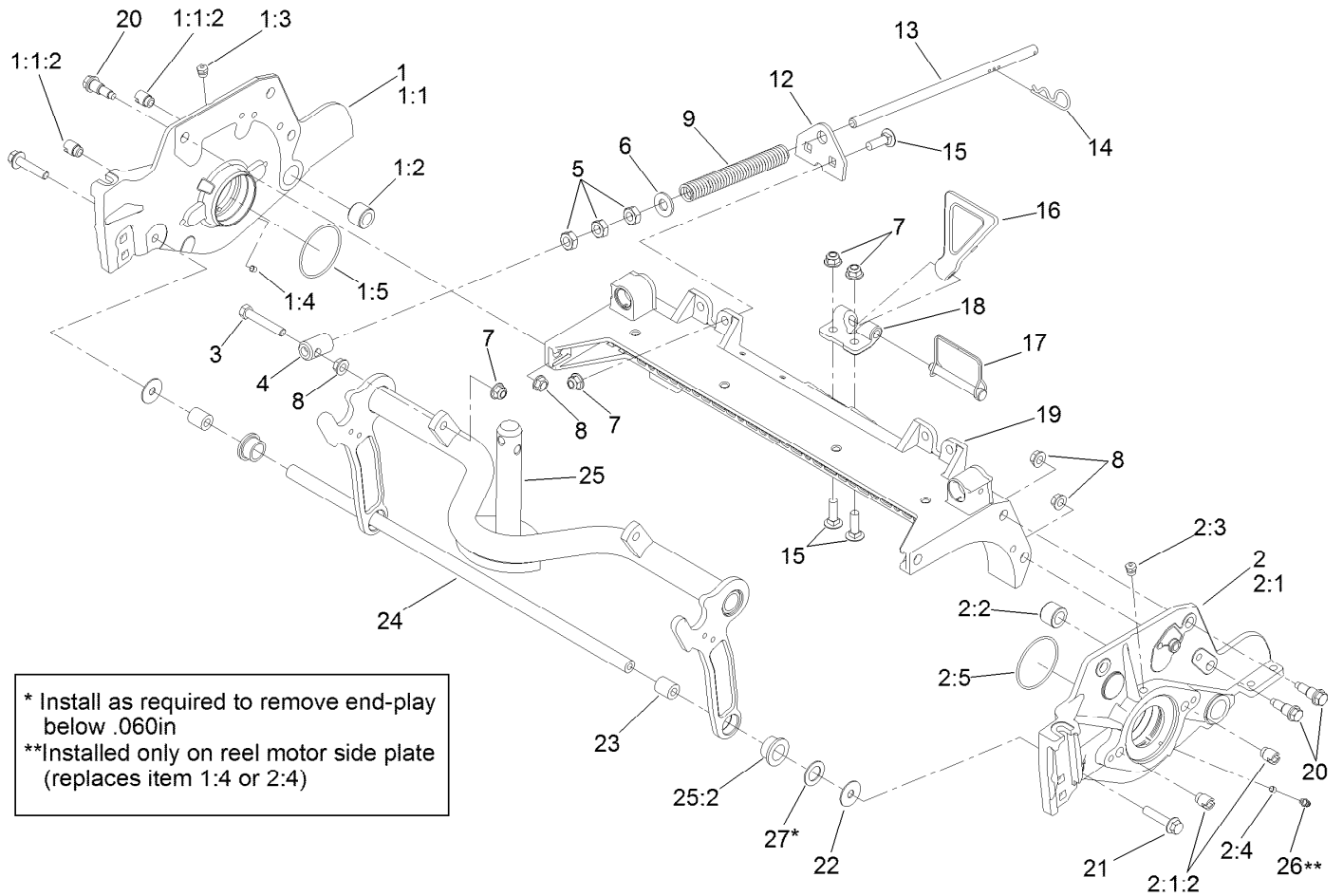

Frame Assembly

Ref.	Part Number	Qty.	Description
1	137-5967	1	7In RH LD Side Plate ASM
1:1		1	Side Plate-7In, RH ■
1:1:2	127-7149	2	Insert-Threaded, Side Plate
1:2	106-9618	1	Bushing-Rubber
1:3	302-39	1	Fitting-Plug
1:4	3245-35	1	Screw-Set, HSH
1:5	117-8177	1	O-Ring
2	137-5963	1	7In LH LD Side Plate ASM
2:1		1	Side Plate-7In, LH ■
2:1:2	127-7149	2	Insert-Threaded, Side Plate
2:2	106-9618	1	Bushing-Rubber
2:3	302-39	1	Fitting-Plug
2:4	3245-35	1	Screw-Set, HSH
2:5	117-8177	1	O-Ring
3	104-3396	1	Screw-HH
4	99-8662	1	Tube-Spring
5	3218-5	3	Nut-Jam
6	87-7270	1	Washer-Thrust
7	104-8301	5	Nut-HF, NI

Ref.	Part Number	Qty.	Description
8	3290-357	7	Nut-HHF, Whiz
9	110-4079	1	Spring-Compression
12	110-4069	1	Bracket
13	115-2007	1	Rod-Spring
14	92-2762	1	Pin-Hair
15	3231-25	4	Bolt-CARR
16	119-8010-03	1	Kickstand ●
17	107-7400	1	Pin-Lynch
18	110-4058	1	Bracket-Chain
19	107-3258	1	Frame
20	107-2979	6	Bolt-Shoulder
21	3234-19	2	Screw-HHF
22	130-8094	2	Washer-Plain
23	108-4279	2	Spacer-Frame
24	108-4284	1	Tube-Support
25	107-7433	1	Carrier Frame ASM
25:2	93-2877	2	Bushing
26	302-5	1	Fitting-Grease
27	67-9410	1	Washer

● Optional Equipment

■ Not serviced separately

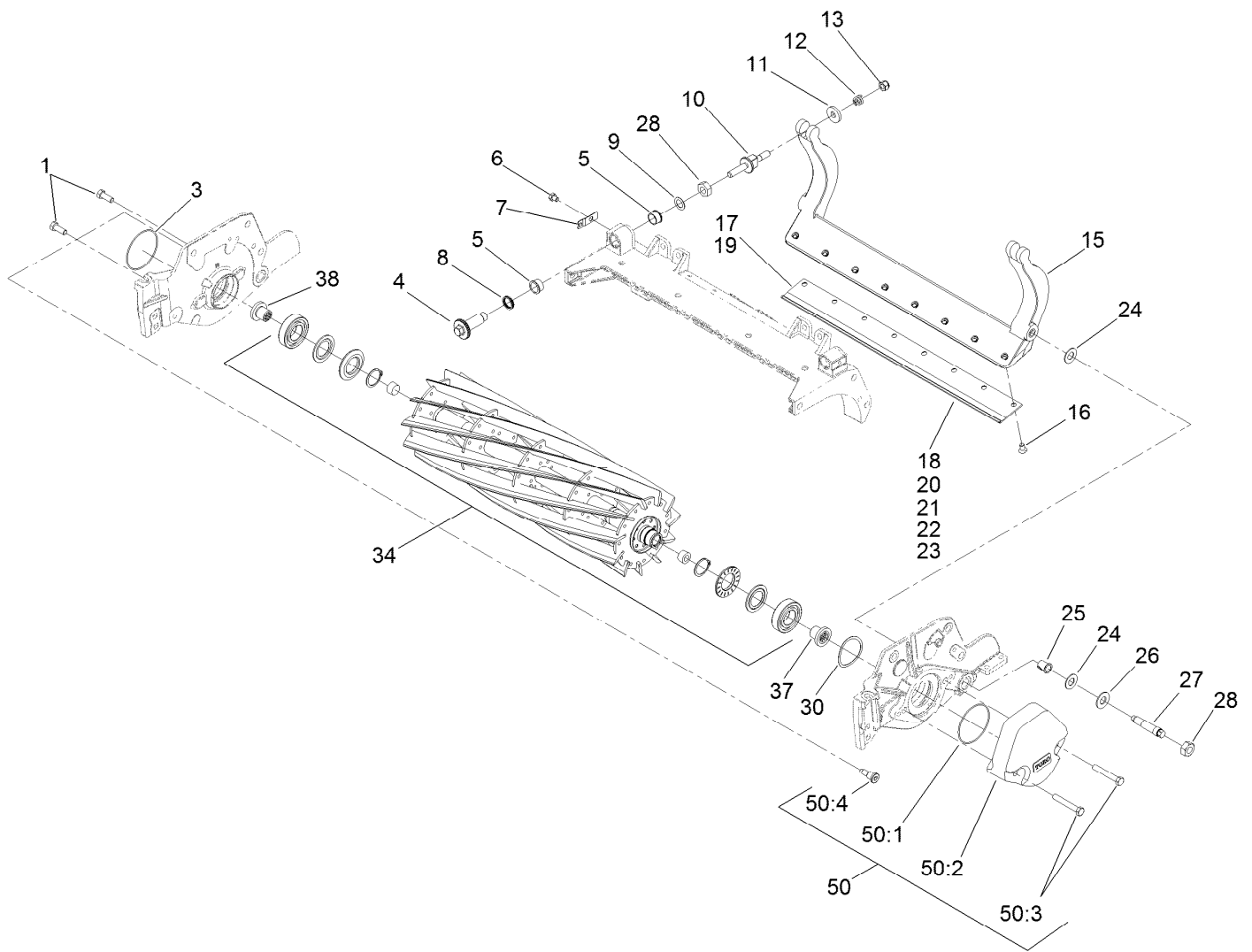

Reel and Bedbar Assembly

Ref.	Part Number	Qty.	Description	Ref.	Part Number	Qty.	Description
1	323-6	2	Screw-HH	19	137-0832	1	Bedknife-Edgemax Lowcut ■
3	112-6967	1	O-Ring	20	110-4084	1	Bedknife-Low HOC (Fairway) ■
4	120-5118	2	Shaft-Adjuster	21	119-4280	1	Bedknife-Edgemax Extended Low HOC, Fairw ■
5	106-5344	4	Bushing-Flange, Keyed	22	120-1640	1	Bedknife-Low HOC Extended, Fairway ■
6	119-4067	2	Screw-HH	23	110-4074	1	Bedknife-HD (Fairway) ■
7	99-2097	2	Detent	24	61-1950	4	Washer-Plastic
8	120-5116	2	Washer-Wave	25	56-9520	2	Bushing-Flanged
9	108-0015	2	Washer-Flat	26	69-8980	2	Washer
10	137-6130	2	Screw-Adjuster, Bedbar	27	106-9623	2	Bolt-Bedbar
11	119-4155	2	Washer-Hardened	28	3296-33	4	Nut-Lock, NI
12	120-5120	2	Spring-Compression	30	115-5258	1	Spring-Wire, Flat
13	119-4039	2	Nut-Hex, NI	34	137-8444	1	ES Reel+,7In Fwy(22)5 Bld LD(Rr) ■
15	107-3273-01	1	Bedbar				
15	131-3221-0P	1	Bedbar-Aggressive, 7In ● ■				
16	119-4151	8	Screw-Bedknife				
17	137-0833	1	Bedknife-Edgemax (Fairway)				
18	108-9096	1	Bedknife-STD (Fairway) ■				

● Not illustrated

■ Optional Equipment

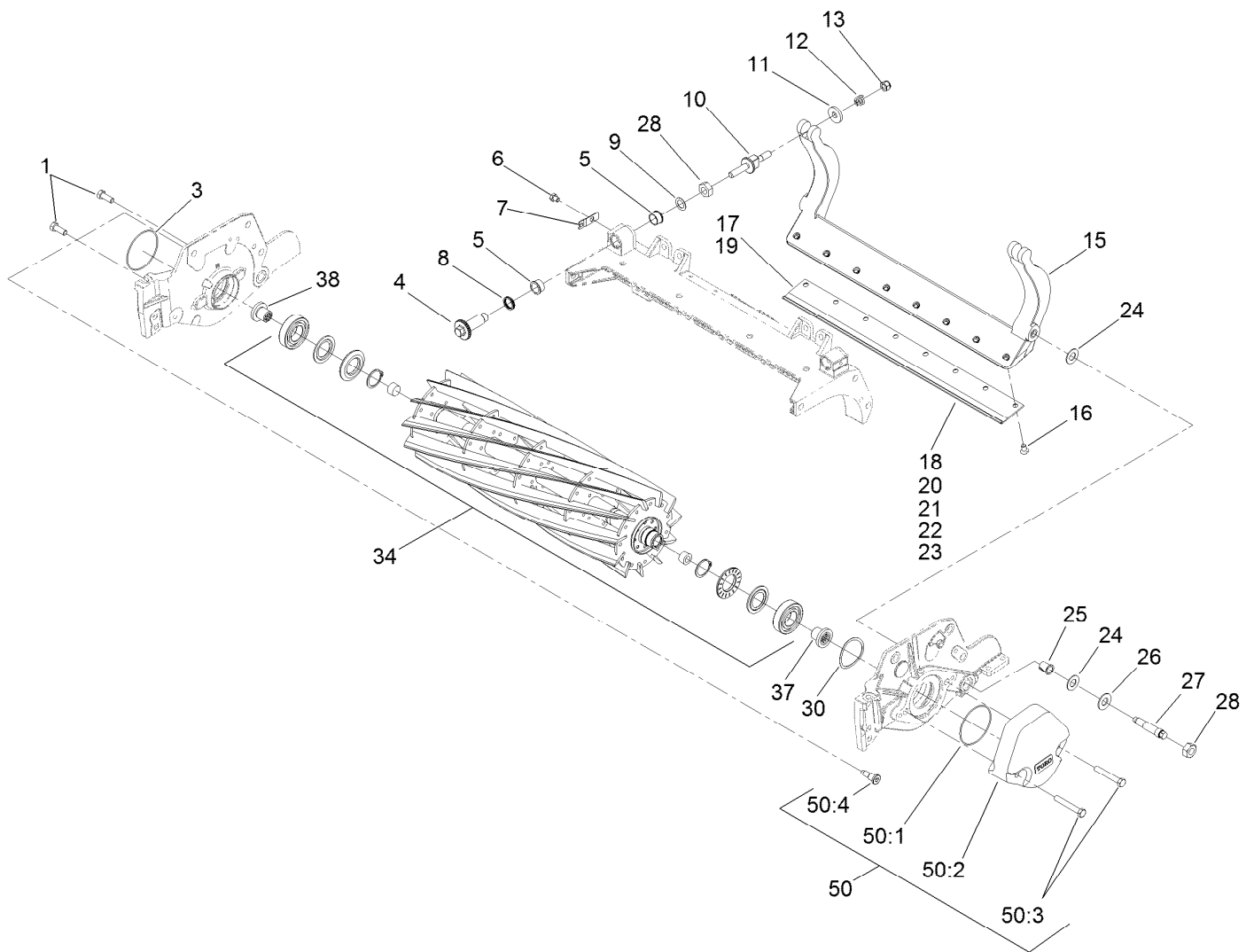

Reel and Bedbar Assembly (continued)

Ref.	Part Number	Qty.	Description
34	137-8446	1	ES Reel+, 7In Fwy(22)8 Bld LD(Fsr)
37	127-7111	1	Insert-Threaded, 7 Inch (LH)
38	127-7109	1	Insert-Threaded, 7 Inch (RH)
45	120-7230	1	Rm HD DPA MVP Kit ●■

Ref.	Part Number	Qty.	Description
50	127-7129	1	Weight Kit ■
50:1	112-6967	5	O-Ring
50:2	108-4269-01	5	Weight
50:3	323-12	10	Screw-HH
50:4	127-7122	5	Bolt-Shoulder, Flange Hex Socket

● Not illustrated

■ Optional Equipment

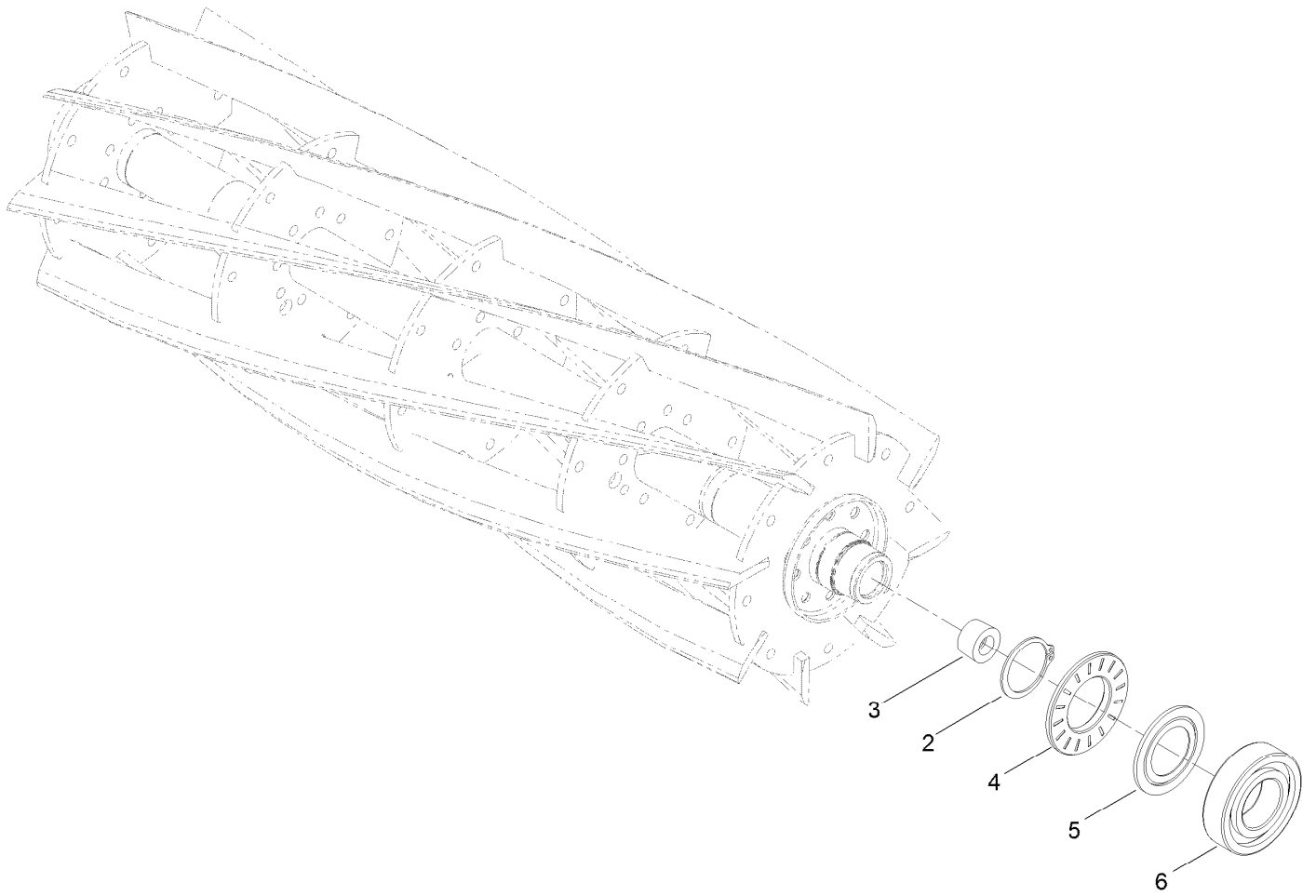

7in EdgeSeries+ 22in Fairway, 8 Blade, Low Drag, Forward Swept Reel Assembly No. 137-8446

<i>Ref.</i>	<i>Part Number</i>	<i>Qty.</i>	<i>Description</i>
2	92-2601	2	Ring-Retaining
3	127-7118	2	Plug-Shaft, Reel
4	127-4284	2	Washer-Special
5	115-3299	2	Seal-Flocked
6	140-5510	2	Bearing-Sealed, Stainless

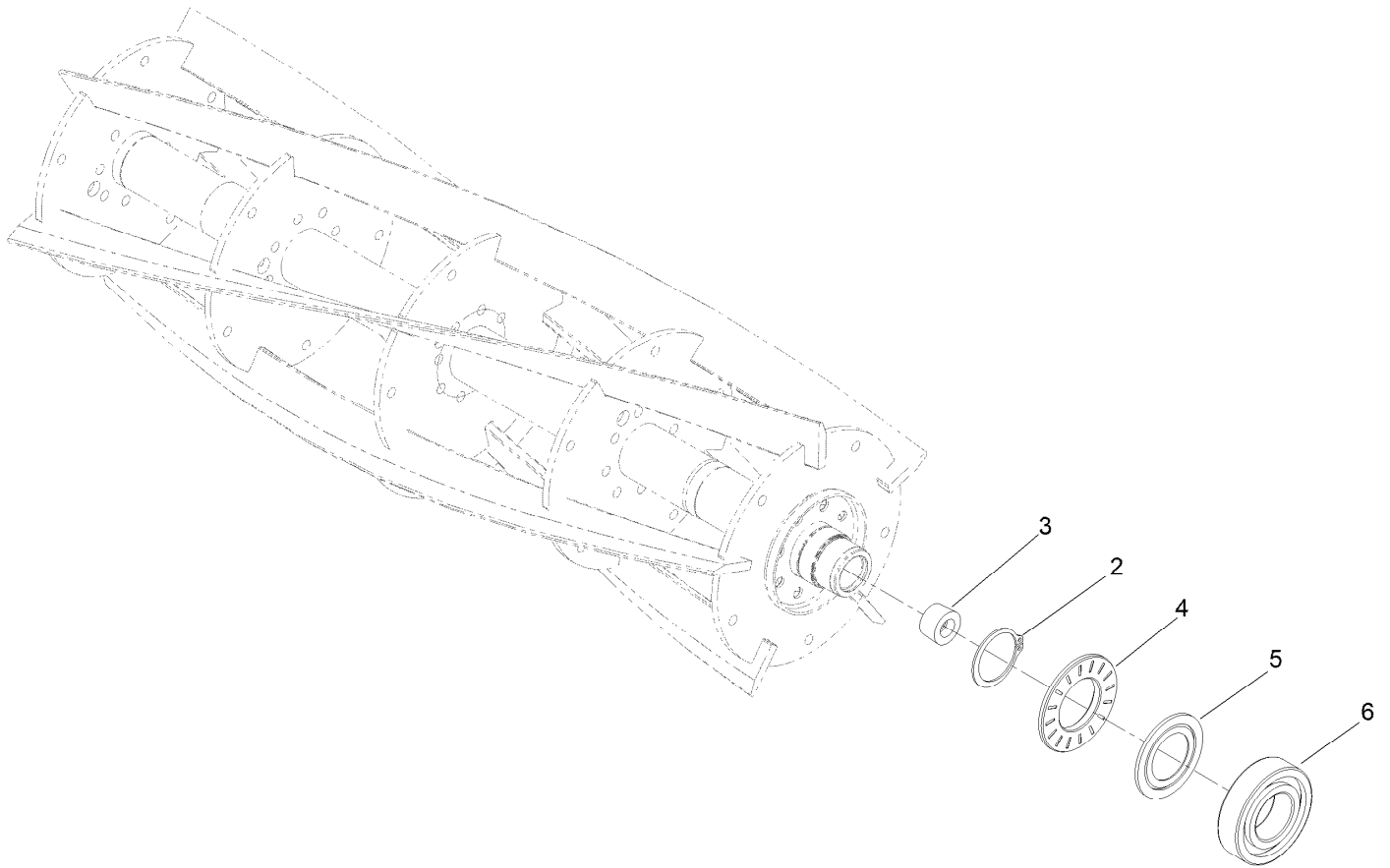

Optional 7in EdgeSeries+ 22in Fairway, 5 Blade Radial Reel Assembly No. 137-8444

<i>Ref.</i>	<i>Part Number</i>	<i>Qty.</i>	<i>Description</i>
2	92-2601	2	Ring-Retaining
3	127-7118	2	Plug-Shaft, Reel
4	127-4284	2	Washer-Special
5	115-3299	2	Seal-Flocked
6	140-5510	2	Bearing-Sealed, Stainless

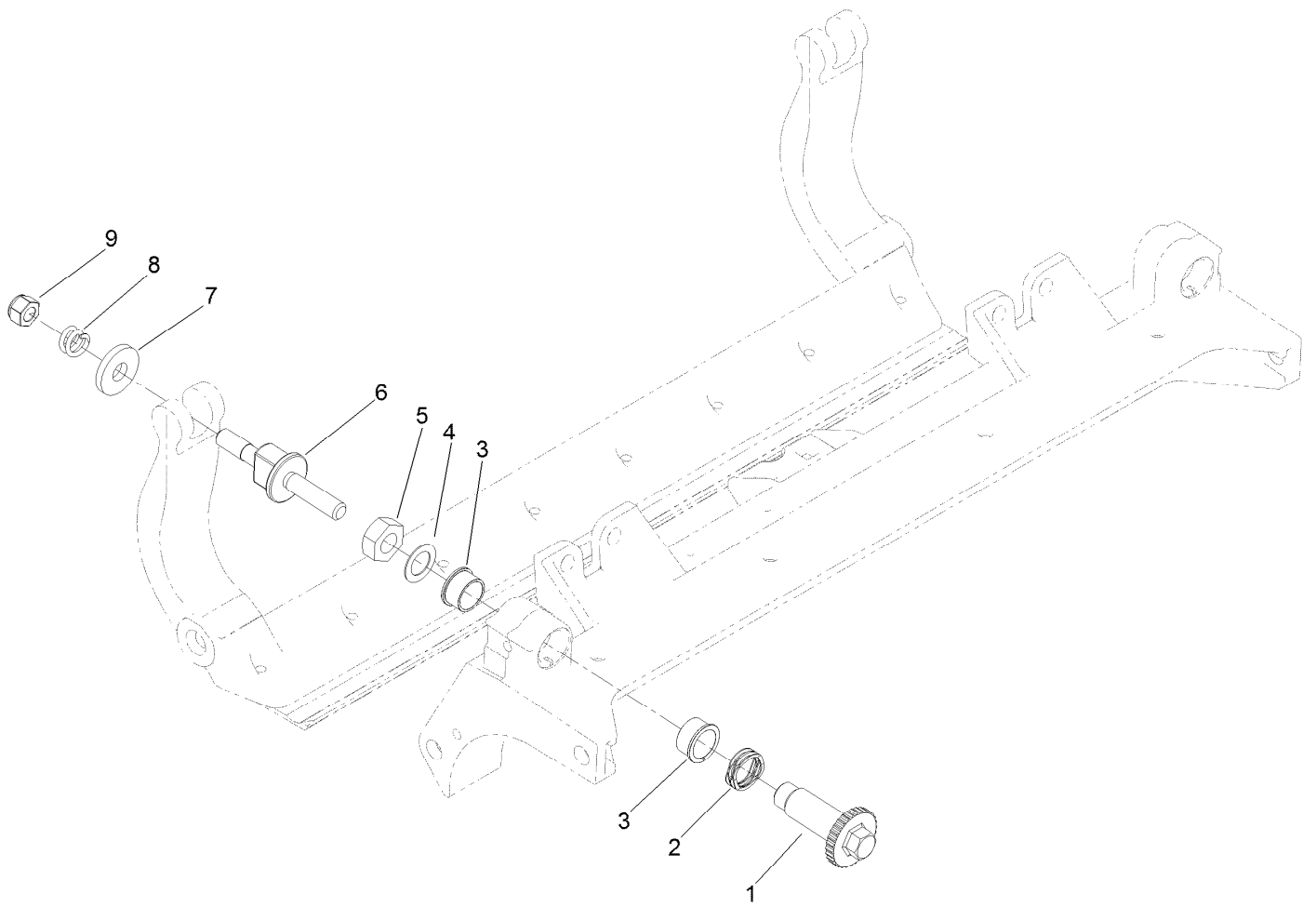

Optional Heavy-Duty MVP Kit No. 120-7230

<i>Ref.</i>	<i>Part Number</i>	<i>Qty.</i>	<i>Description</i>
1	120-5118	2	Shaft-Adjuster
2	120-5116	2	Washer-Wave
3	106-5344	4	Bushing-Flange, Keyed
4	108-0015	2	Washer-Flat
5	3296-33	2	Nut-Lock, NI
6	137-6130	2	Screw-Adjuster, Bedbar
7	119-4155	2	Washer-Hardened
8	120-5120	2	Spring-Compression
9	119-4039	2	Nut-Hex, NI

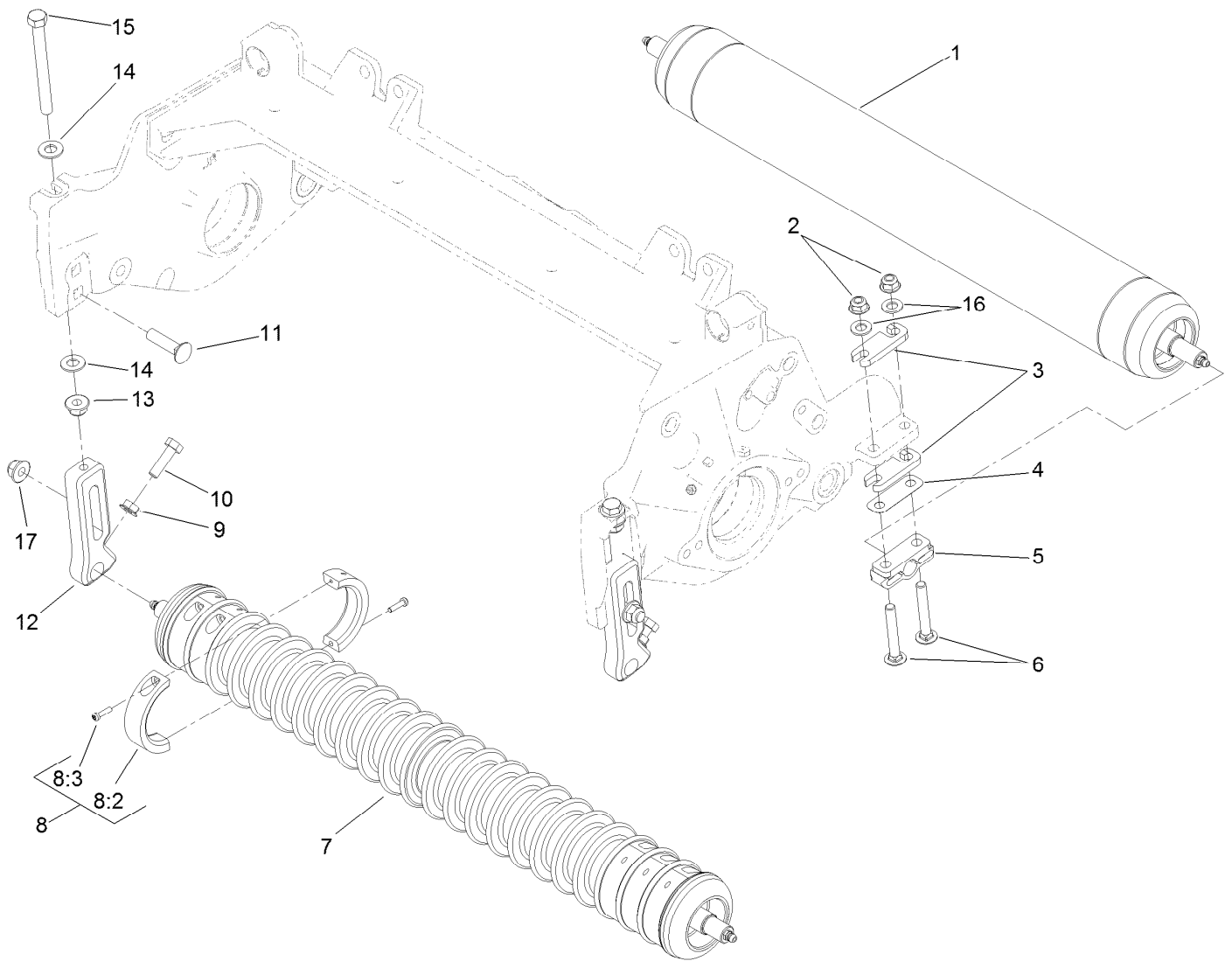

Roller Assembly

Ref.	Part Number	Qty.	Description	Ref.	Part Number	Qty.	Description
1	137-6113	1	Long Rear Roller ASM (3In DIA)(22In)	8	104-8215	6	Collar Kit ■
1	137-6117	1	Short Rear Roller ASM (3In DIA)(22In) ● ■	8:2	100-4959	2	Collar
2	104-8300	4	Nut-HF, NI	8:3	104-1835	2	Screw
3	119-0626	8	Shim-Roller	9	32128-20	2	Nut-HF
4	140-5530	2	Shim-Roller (.01") ■	10	322-16	2	Screw-HH
5	106-3924	2	Bracket-Roller, Rear	11	3231-4	2	Screw-CARR
6	3230-26	4	Screw-CARR	12	125-2796	2	Bracket-Front HOC
7	114-5400	1	Plastic Wiehle Roller ASM	13	104-8301	2	Nut-HF, NI
7	114-5421	1	Plastic Shoulder Roller ASM ● ■	14	48-9220	4	Washer-Plain
7	137-6111	1	Full Front Roller ASM (3In DIA)(22In) ● ■	15	140-5522	2	Screw-HHF 5/8, Patch
				16	94-6936	4	Washer-Hardened
				17	133-7570	2	Nut-Flange, NI
				50	137-0890	1	Rm DPA High HOC Kit (F18 & Up) ● ■

● Not illustrated

■ Optional Equipment

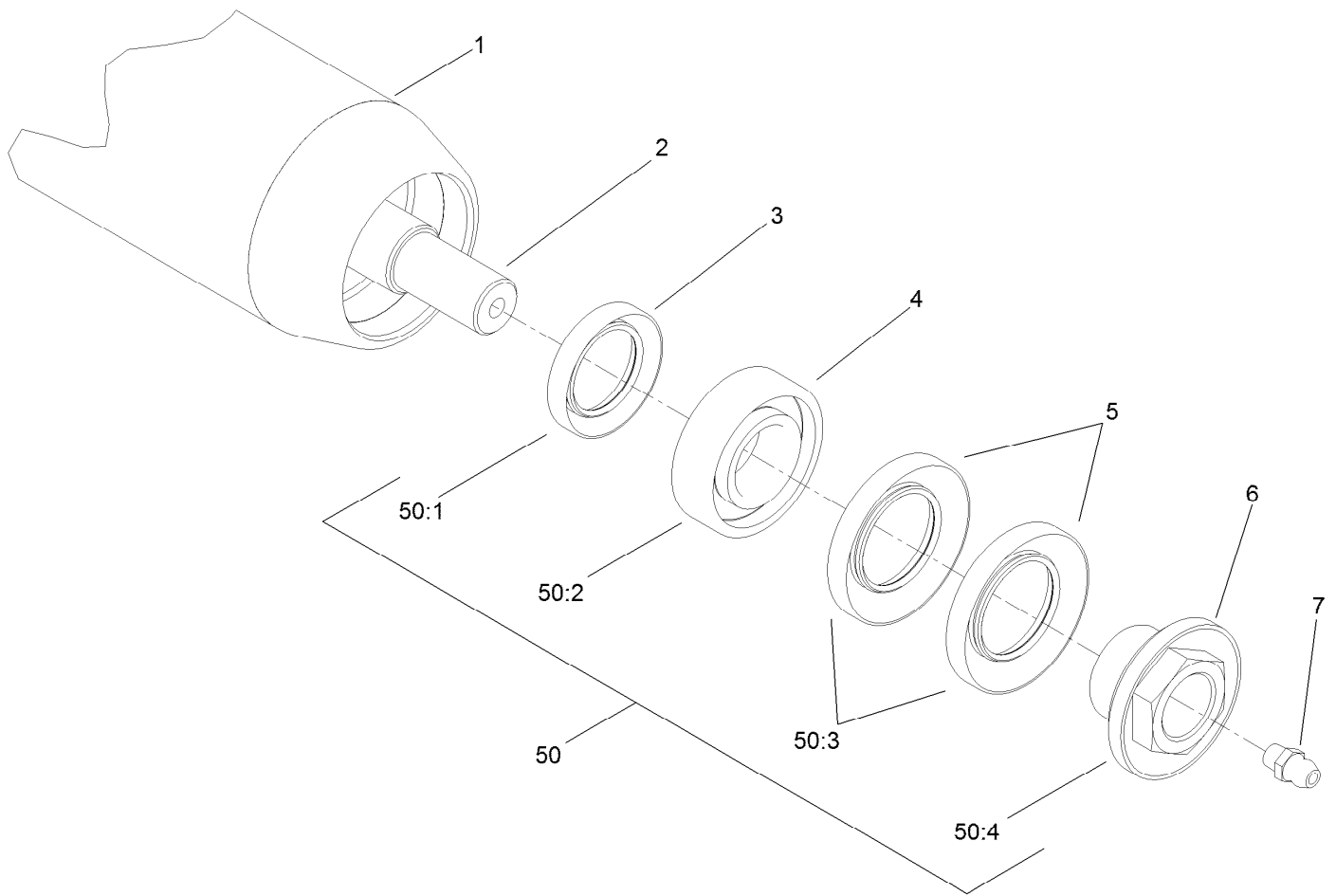

3 Inch Diameter Long Roller Assembly No. 137-6113

<i>Ref.</i>	<i>Part Number</i>	<i>Qty.</i>	<i>Description</i>
1	137-6112	1	Tube Roller 3.0In DIA X 23In
2	114-5407	1	Shaft-Long, Rear Roller
3	114-3717	2	Seal-Oil
4	112-5290	2	Bearing-Steel, Stainless
5	112-7494	4	Seal
6	114-5411	2	Nut-Lock, Bearing
7	302-5	2	Fitting-Grease
50	114-5430	1	Roller Rebuild Kit ●
50:1	114-3717	2	Seal-Oil
50:2	112-5290	2	Bearing-Steel, Stainless
50:3	112-7494	4	Seal
50:4	114-5411	2	Nut-Lock, Bearing

● Optional Equipment

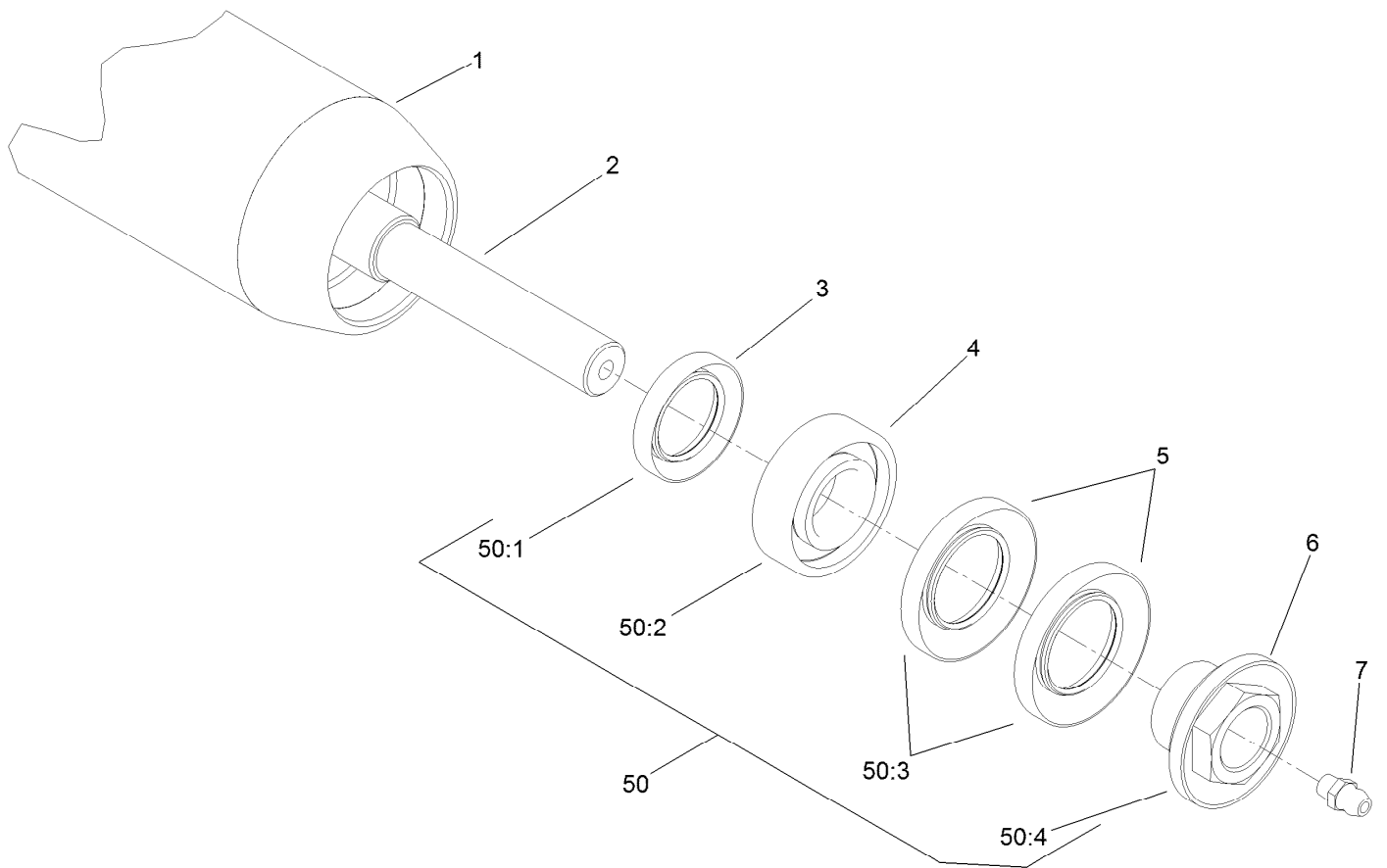

Optional 3 Inch Diameter Short Roller Assembly No. 137-6117

<i>Ref.</i>	<i>Part Number</i>	<i>Qty.</i>	<i>Description</i>
1	137-6115	1	Tube Roller 3.0In DIA X 20.5In
2	114-5410	1	Shaft-Short, Rear Roller
3	114-3717	2	Seal-Oil
4	112-5290	2	Bearing-Steel, Stainless
5	112-7494	4	Seal
6	114-5411	2	Nut-Lock, Bearing
7	302-5	2	Fitting-Grease
50	114-5430	1	Roller Rebuild Kit ●
50:1	114-3717	2	Seal-Oil
50:2	112-5290	2	Bearing-Steel, Stainless
50:3	112-7494	4	Seal
50:4	114-5411	2	Nut-Lock, Bearing

● Optional Equipment

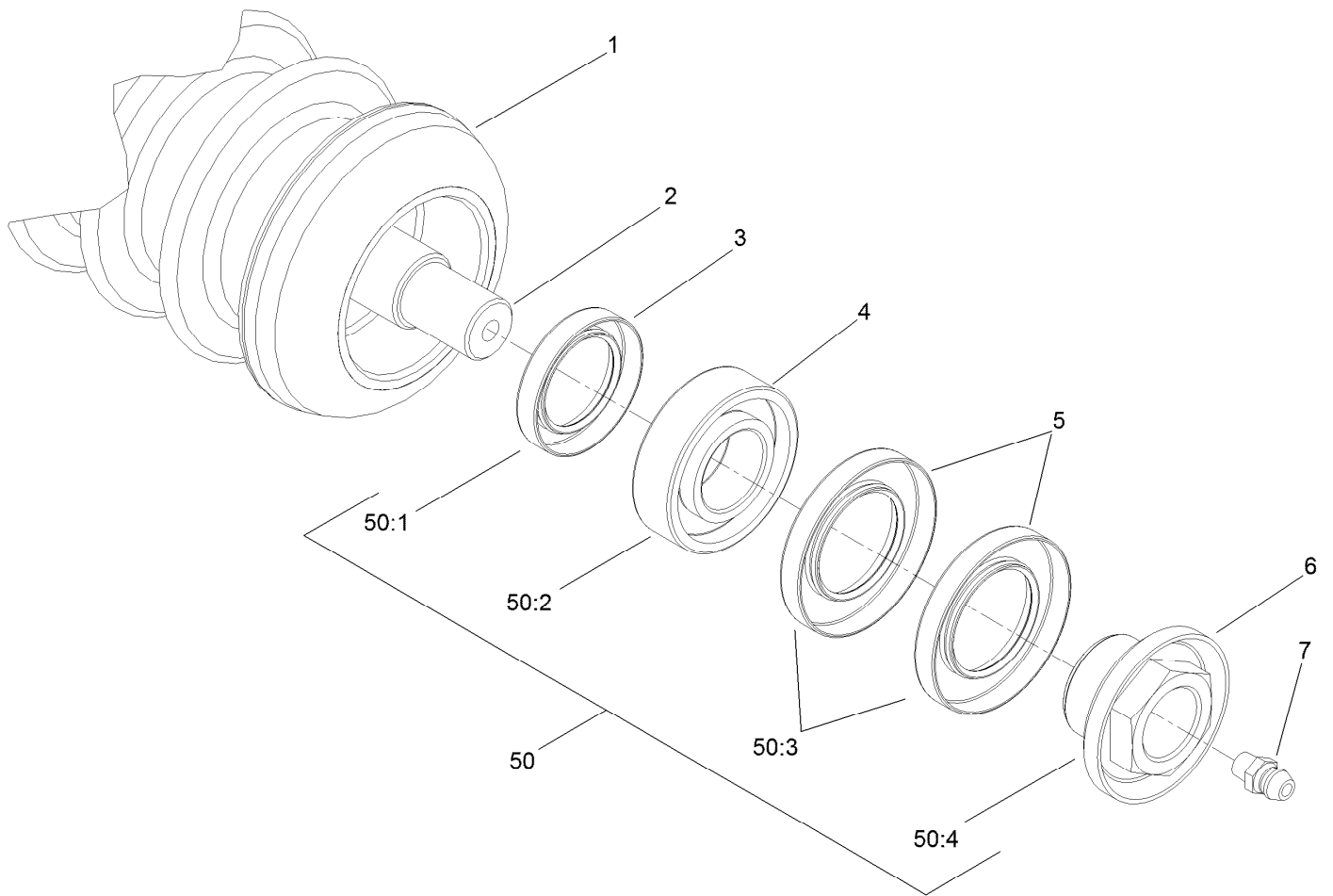

Plastic Wiehle Roller Assembly No. 114-5400

<i>Ref.</i>	<i>Part Number</i>	<i>Qty.</i>	<i>Description</i>
1	114-5401	1	Wiehle Roller Plastic (22In)
2	114-5403	1	Shaft-Roller, Front
3	114-3717	2	Seal-Oil
4	112-5290	2	Bearing-Steel, Stainless
5	112-7494	4	Seal
6	114-5411	2	Nut-Lock, Bearing
7	302-5	2	Fitting-Grease
50	114-5430	1	Roller Rebuild Kit ●
50:1	114-3717	2	Seal-Oil
50:2	112-5290	2	Bearing-Steel, Stainless
50:3	112-7494	4	Seal
50:4	114-5411	2	Nut-Lock, Bearing

● Optional Equipment

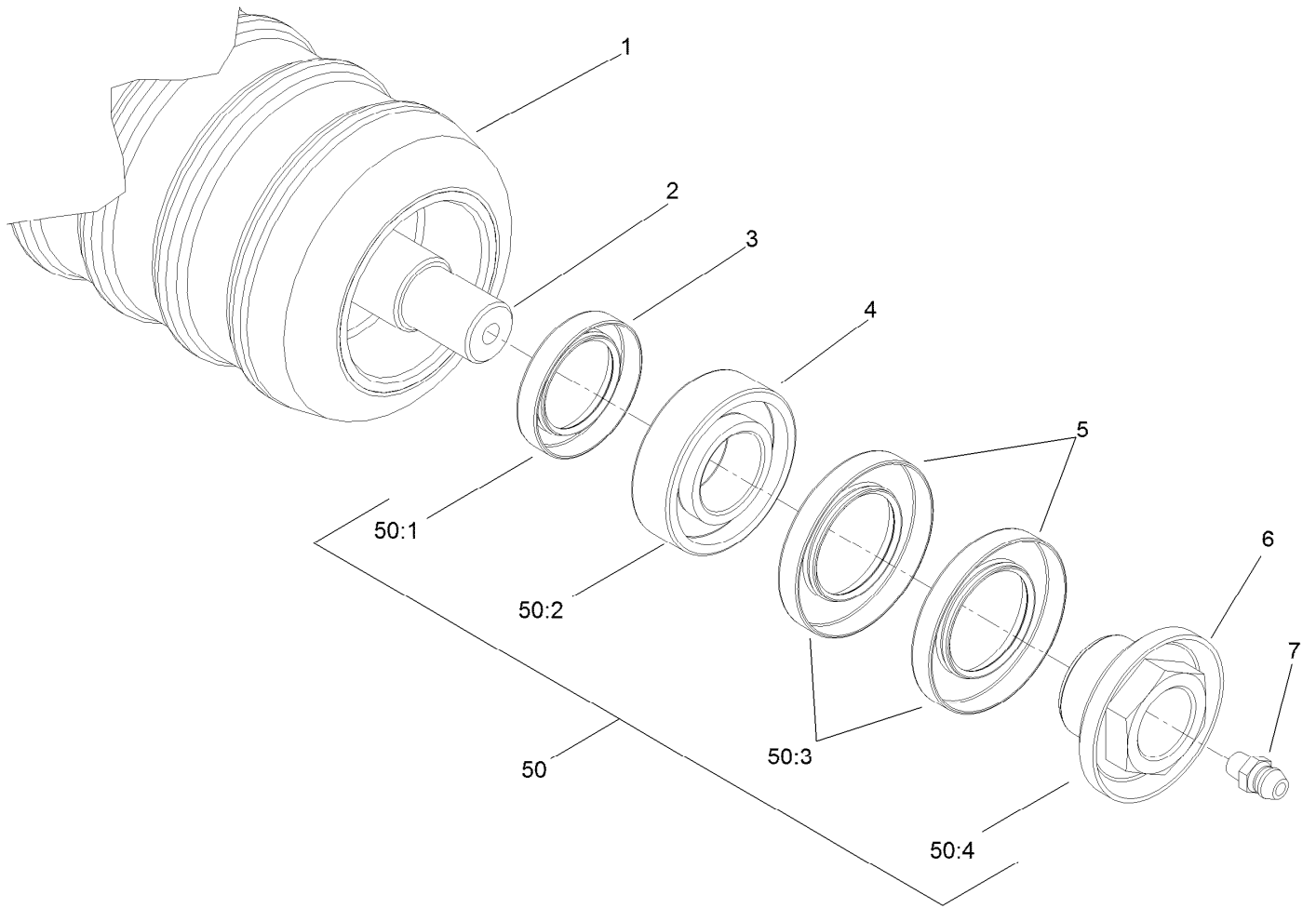

Optional Plastic Shoulder Roller Assembly No. 114-5421

<i>Ref.</i>	<i>Part Number</i>	<i>Qty.</i>	<i>Description</i>
1	114-5422	1	Roller-Shoulder, Plastic
2	114-5403	1	Shaft-Roller, Front
3	114-3717	2	Seal-Oil
4	112-5290	2	Bearing-Steel, Stainless
5	112-7494	4	Seal
6	114-5411	2	Nut-Lock, Bearing
7	302-5	2	Fitting-Grease
50	114-5430	1	Roller Rebuild Kit ●
50:1	114-3717	2	Seal-Oil
50:2	112-5290	2	Bearing-Steel, Stainless
50:3	112-7494	4	Seal
50:4	114-5411	2	Nut-Lock, Bearing

● Optional Equipment

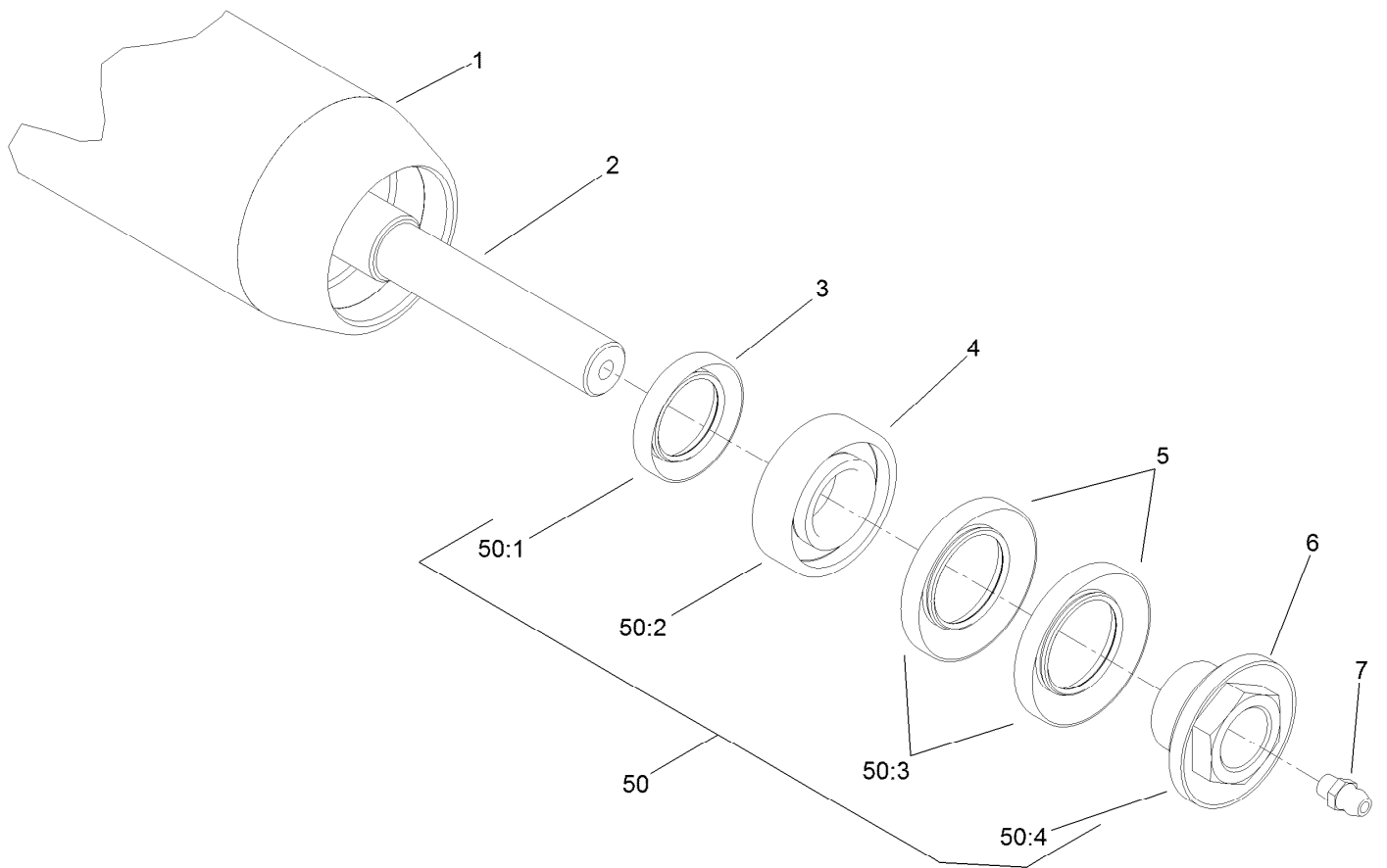

Optional Full Front Roller Assembly No. 137-6111

<i>Ref.</i>	<i>Part Number</i>	<i>Qty.</i>	<i>Description</i>
1	137-6110	1	Tube Roller 3.0In DIA X 24.5In
2	114-5403	1	Shaft-Roller, Front
3	114-3717	2	Seal-Oil
4	112-5290	2	Bearing-Steel, Stainless
5	112-7494	4	Seal
6	114-5411	2	Nut-Lock, Bearing
7	302-5	2	Fitting-Grease
50	114-5430	1	Roller Rebuild Kit ●
50:1	114-3717	2	Seal-Oil
50:2	112-5290	2	Bearing-Steel, Stainless
50:3	112-7494	4	Seal
50:4	114-5411	2	Nut-Lock, Bearing

● Optional Equipment

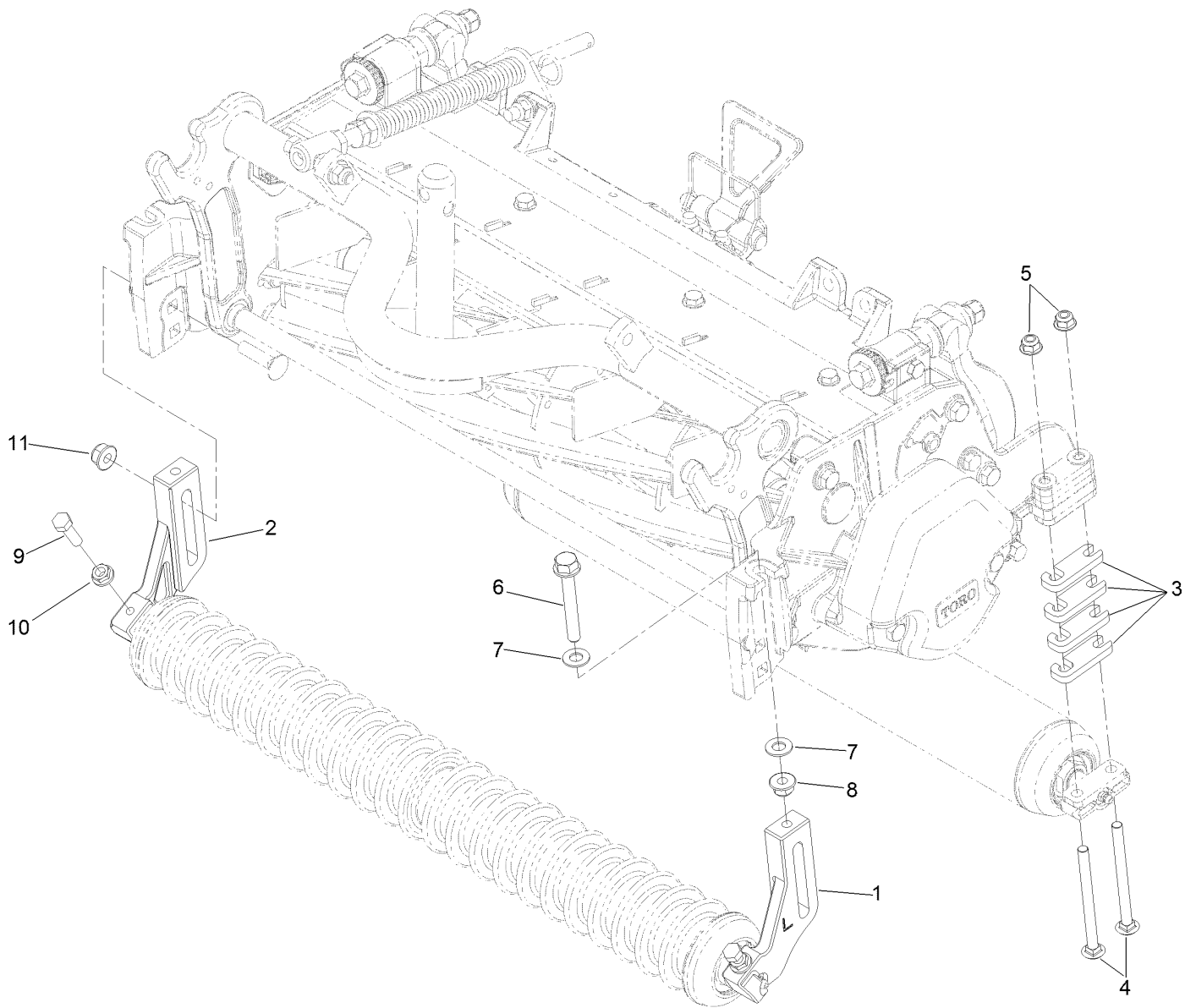

Optional High Height-of-Cut Assembly No. 137-0890

<i>Ref.</i>	<i>Part Number</i>	<i>Qty.</i>	<i>Description</i>
1	120-0404	1	Bracket-High HOC (LH)
2	120-0405	1	Bracket-High HOC (RH)
3	119-0626	8	Shim-Roller
4	106-9758	4	Screw-CARR
4	3230-30	4	Screw-CARR
5	104-8300	4	Nut-HF, NI
6	140-5523	2	Screw-HHF 5/8, Patch
7	48-9220	4	Washer-Plain
8	104-8301	4	Nut-HF, NI
9	322-16	2	Screw-HH
10	32128-20	2	Nut-HF
11	133-7570	2	Nut-Flange, NI

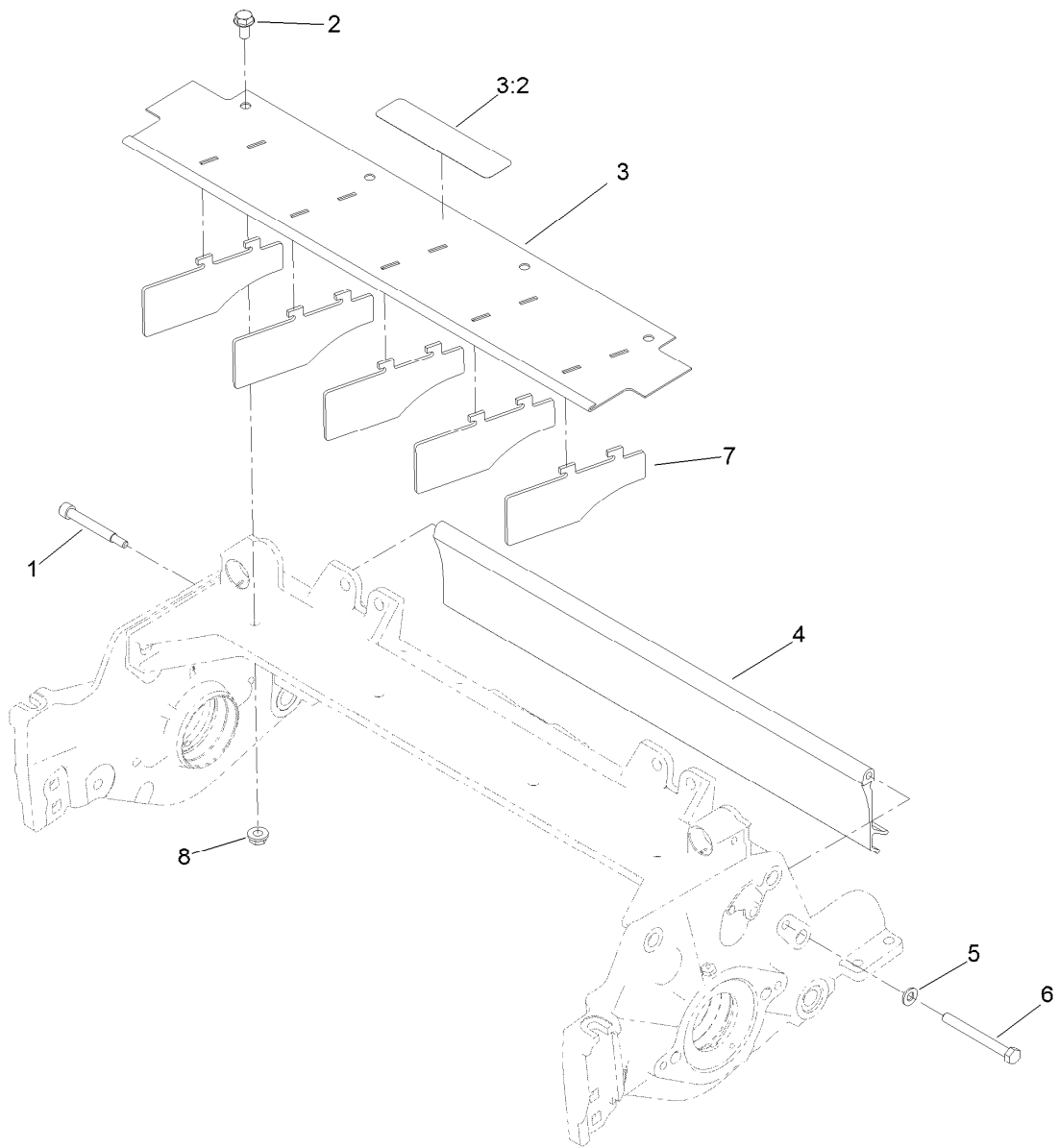

Shield Assembly

Ref.	Part Number	Qty.	Description
1	107-7773	1	Screw-HSH
2	3234-7	4	Screw-HHF
3	107-2996	1	Front Glass Shield ASM
3:2	137-9706	1	Decal-Warning
4	125-1978	1	Shield-Glass, Rear
5	3256-74	1	Washer-Flat
6	322-14	1	Screw-HH
7	110-1706	5	Deflector
8	32128-20	4	Nut-HF

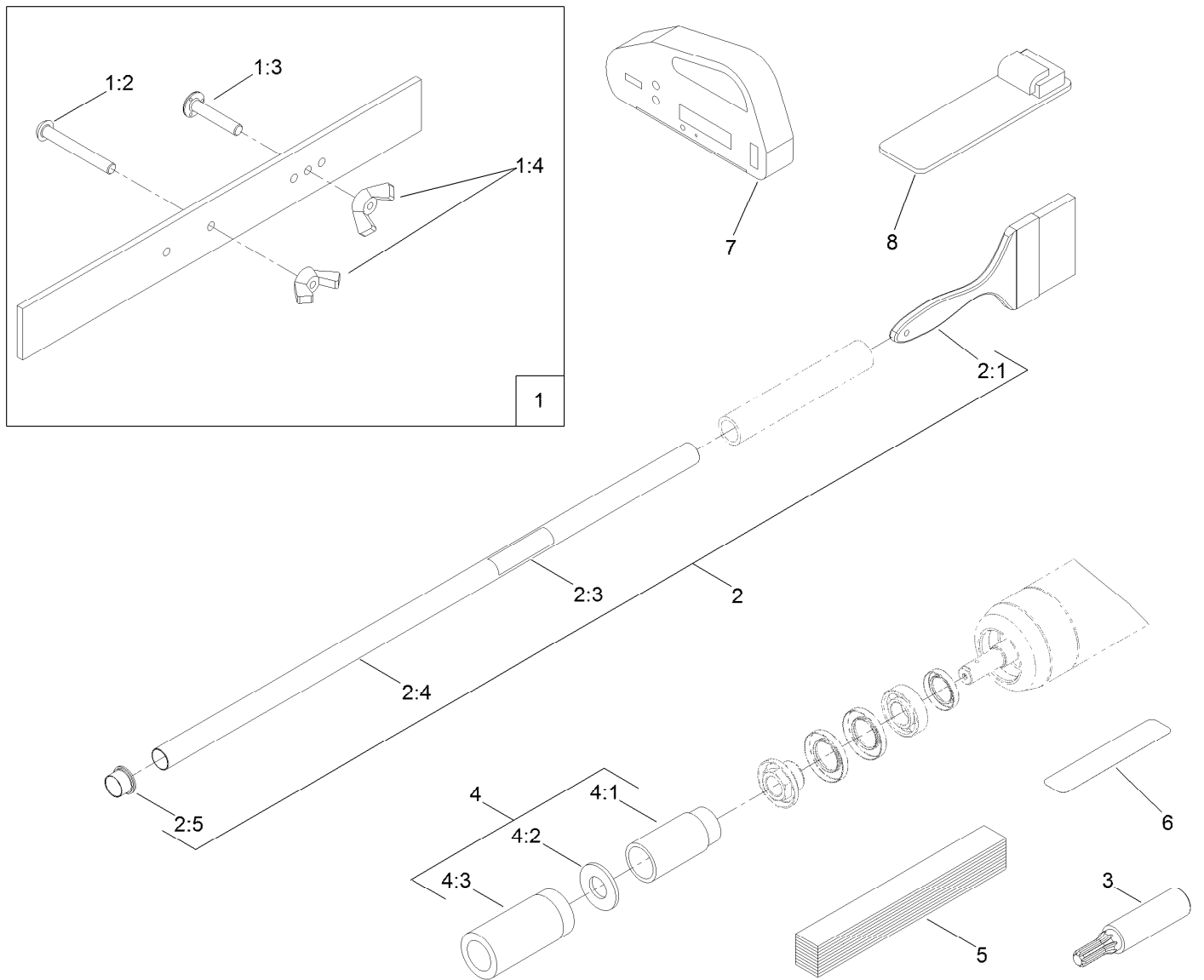

Optional Tool Assembly

Ref.	Part Number	Qty.	Description
1	108-6715	1	Gauge Bar ASM
1:2	32122-54	1	Screw-Head, Truss
1:3	108-6714	1	Stud-Weld
1:4	32103-3	2	Nut-Wing
2	29-9100	1	Brush And Handle ASM
2:1	36-4310	1	Brush
2:3	98-3206	1	Decal
2:4	29-9080	1	Handle
2:5	2410-18	1	Cap-Plastic
3	TOR4074	1	Adapter-Drive, Reel ■
4	115-0803	1	Rm/Gm Roller Rebuild Tool Kit

Ref.	Part Number	Qty.	Description
4:1	115-0852	1	Tool-Inner Seal
4:2	107-8133	1	Washer-Flat
4:3	115-0853	1	Tool-Bearing/Outer Seal
5	125-5610	1	Paper-Reel, Toro (10 Pack)
6	140-5531	1	Shim-Toro Reel (.002In)
7	131-6828	1	Indicator-Angle
8	131-6829	1	Mount-Indicator, Angle
9	137-0924	1	Tool-Hand TAP 7/8-16 (Rm DPA Reel) ●
10	137-0925	1	Tool-Hand TAP 7/8-16, LH (Rm DPA Reel) ●

● Not illustrated

■ Obtain directly from K-Line Industries, Inc. (<https://klineind.com>)

Attachments and Accessories

For 03639 8-Blade EdgeSeries Forward Swept Reel DPA Cutting Unit with 7in Reel Reelmaster 5010 Series Traction Unit

Product Name	Model/Part
Verticutter for 7in Reel Cutting Unit.....	03619
Rear Roller Brush Kit (7in Reel).....	03408
Weight Kit for 8-Blade or 11-Blade DPA Cutting Unit with 7in Reel Traction Unit.....	03405
22in Fairway Flex Grass Basket Kit.....	03415
22in Fairway Compact Grass Basket Kit.....	03416
Rear Lift Cylinder Limit Kit.....	110-9604
Groomer Rod Kit.....	131-6845
Rear Roller Scraper Kit.....	107-3280
Wiehle Scraper ASM.....	107-2993-03
Comb/Scraper Kit.....	110-1735
Full Front Roller Asm (3in Dia)(22in).....	137-6111
3in Full Front Roller Scraper.....	110-9602-03
Plastic Shoulder Roller ASM.....	114-5421
Shoulder Roller Scraper ASM.....	110-9609-03
Brush-Roller (High Height-Of-Cut).....	110-1740
22in Rear Roller HD Brush.....	137-0842
High Height-of-Cut Kit, Reelmaster 3000 or 5000 Series DPA Cutting Unit.....	137-0890
Reel Drive Adapter.....	TOR4074
3in Dia Collar Kit.....	104-8215
Cutting Unit Kickstand.....	119-8010-03
Roller Rebuild Tool Kit.....	115-0803
Gauge Bar Assembly.....	108-6715
Roller Rebuild Kit.....	114-5430
Bedbar-Aggressive, 7in.....	131-3221-0P
Groomer/RRB Seal Kit.....	131-3233
Heavy-Duty DPA MVP Kit.....	120-7230
Rear Roller Adjustment Kit.....	125-0570
Toro Reel Paper (10 Pack).....	125-5610
Shim-TORO Reel (.002in).....	140-5531
Bedknife-Edgemax (Fairway).....	137-0833
Bedknife-STD (Fairway).....	108-9096
Bedknife-Edgemax Lowcut.....	137-0832
Bedknife-Low HOC (Fairway).....	110-4084
Bedknife Edgemax Low cut Extended (Fairway).....	119-4280
Bedknife-Lowcut Extended (Fairway).....	120-1640
Bedknife-HD (Fairway).....	110-4074
EdgeSeries+ Reel 7in Fairway(22in) 5 Blade Low Drag(Radial Reel).....	137-8444
Angle Indicator.....	131-6828
Angle Indicator Mount.....	131-6829
EdgeSeries+ Reel, 7in Fairway(22in) 8 Blade Low Drag(Forward Swept Reel).....	137-8446
Universal Groomer Drive Kit.....	03768
Rear Roller Brush Kit for Units with 7in Reel and Universal Groomer (22in).....	03659
Weight Kit for Units with 5 Inch Electric Reel or 7 Inch Electric or Hydraulic Reel and Universal Groomer Only.....	03418

Attachments and Accessories (continued)

Weight Kit for Units with 5 Inch Electric Reel or 7 Inch Electric or Hydraulic Reel and Universal Groomer with Rear Roller Brush	03419
Universal Groomer Drive MVP Kit, Reelmaster 3575, 5010, and 5010-H Series 22-inch Cutting Units with 7 Inch Reel	133-0151
Universal Groomer Cartridge, Reelmaster 3555, 3575, 5010, and 5010-H Series 22-inch EdgeSeries Cutting Units with Universal Groomer	03772
Rear Roller Brush MVP Kit, Reelmaster 5010-H Series 22-inch Cutting Unit with 7-inch Reel and Universal Groomer	133-0154
Grooming Brush (22In)	03767
Rear Roller Brush MVP Kit, Reelmaster 5010-H Series Cutting Unit with 7 Inch Reel	133-0158
Broomer Kit (22In)	132-7125
LH 7in Heavy Duty Low Drag Side Plate ASM	137-5982
RH 7in Heavy Duty Low Drag Side Plate ASM	137-5983
Tool-hand Tap 7/8-16 (RM DPA Reel)	137-0924
Tool-hand Tap 7/8-16, LH (RM DPA Reel).....	137-0925

Notes:

Notes:

Notes:



Count on it.