



**Count on it.**

**Parts Catalog**

**8-Blade EdgeSeries™ Forward Swept Reel DPA Cutting Unit with 7in Reel**

**Reelmaster® 5010 Series Traction Unit**

Model No. 03639—Serial No. 405700000 and Up



# Ordering Replacement Parts

To order replacement parts, please supply the part number, the quantity, and the description of each part desired.

## Understanding Reference Numbers

Each identified part in an illustration has a reference number. The reference number for a part also appears in the parts list, along with other information about the part.

This catalog uses two special reference number formats, one to indicate parts in a service assembly and another to indicate the quantity of a given part in an illustration.

## Service Assembly Reference Numbers

Parts in service assemblies have reference numbers in the form a:b. The a represents the reference number of the entire service assembly and the b represents a sequential number unique to each part within the service assembly.

For example, a wheel assembly might be identified by reference number 6, the tire by 6:1, the valve by 6:2, and the wheel by 6:3. When you order the assembly identified by reference number 6, you receive all parts identified by reference numbers 6:1, 6:2, and 6:3. However, you may also order any part individually. Reference numbers of this type appear in illustration and in parts lists.

## Reference Numbers Indicating Quantity

In an illustration, if a reference number indicates more than one part, the reference number has the form nX y. The n represents the quantity of the part, the X is the multiplication symbol, and the y represents the reference number.

For example, in an illustration, the reference number 2X 37 means that two of the parts identified by reference number 37 are indicated.

# Contents

Frame Assembly.....	4
Reel and Bedbar Assembly .....	5
7in EdgeSeries+ 22in Fairway, 8 Blade, Low Drag, Forward Swept Reel Assembly No. 137-8446 .....	7
Optional 7in EdgeSeries+ 22in Fairway, 5 Blade Radial Reel Assembly No. 137-8444.....	8
Optional Heavy-Duty MVP Kit No. 120-7230.....	9
Roller Assembly .....	10
3 Inch Diameter Long Roller Assembly No. 114-5415 .....	11
Optional 3 Inch Diameter Short Roller Assembly No. 137-6117 .....	12
Plastic Wiehle Roller Assembly No. 114-5400.....	13
Optional Plastic Shoulder Roller Assembly No. 114-5421 .....	14
Optional Full Front Roller Assembly No. 137-6111 .....	15
Optional High Height-of-Cut Assembly No. 137-0890 .....	16
Shield Assembly.....	17
Optional Tool Assembly.....	18
Attachments and Accessories .....	19

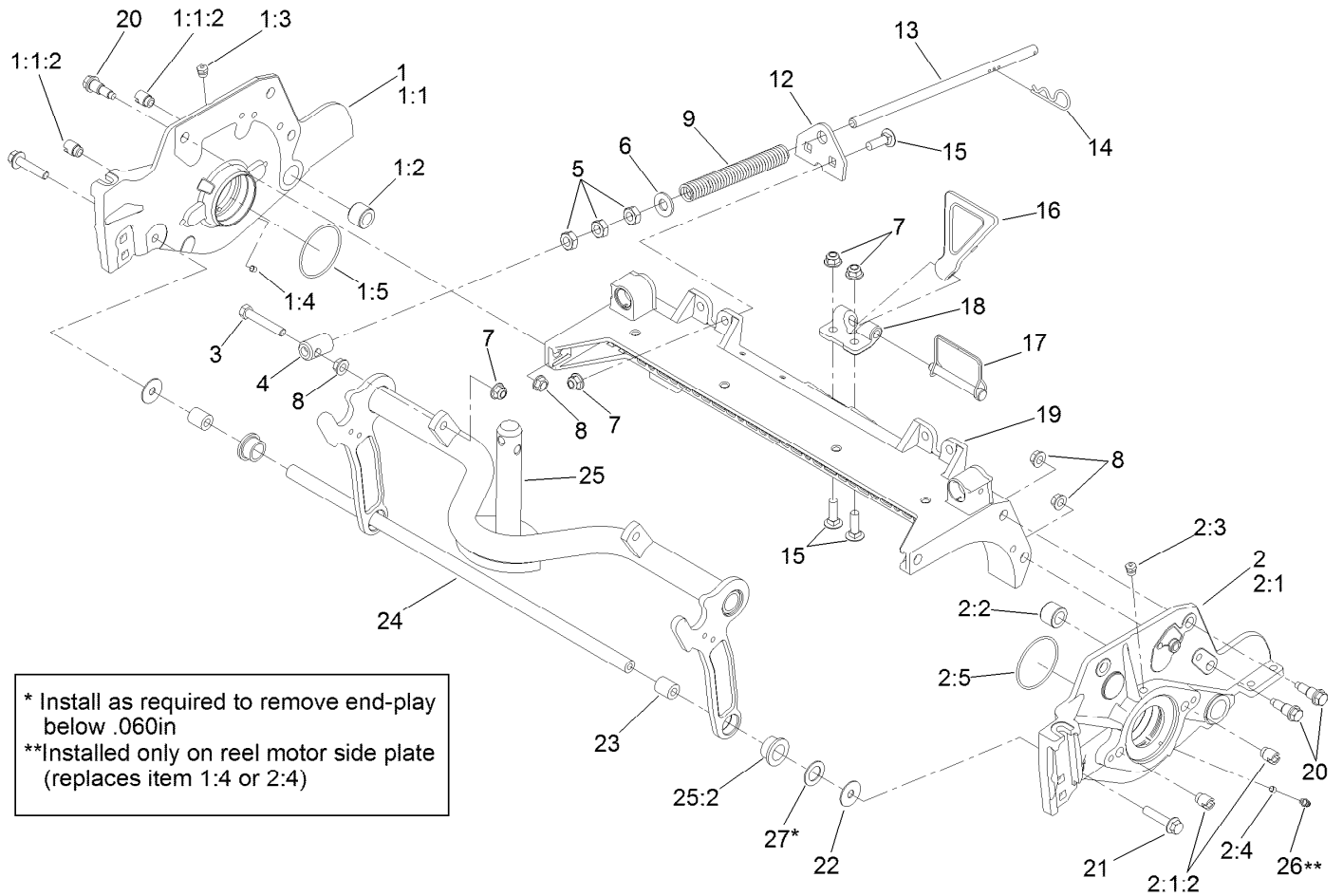

## Frame Assembly

Ref.	Part Number	Qty.	Description
1	137-5967	1	7In RH LD Side Plate ASM
1:1		1	Side Plate-7In, RH ■
1:1:2	127-7149	2	Insert-Threaded, Side Plate
1:2	106-9618	1	Bushing-Rubber
1:3	302-39	1	Fitting-Plug
1:4	3245-35	1	Screw-Set, HSH
1:5	117-8177	1	O-Ring
2	137-5963	1	7In LH LD Side Plate ASM
2:1		1	Side Plate-7In, LH ■
2:1:2	127-7149	2	Insert-Threaded, Side Plate
2:2	106-9618	1	Bushing-Rubber
2:3	302-39	1	Fitting-Plug
2:4	3245-35	1	Screw-Set, HSH
2:5	117-8177	1	O-Ring
3	104-3396	1	Screw-HH
4	99-8662	1	Tube-Spring
5	3218-5	3	Nut-Jam
6	87-7270	1	Washer-Thrust
7	104-8301	5	Nut-HF, NI

Ref.	Part Number	Qty.	Description
8	3290-357	7	Nut-HHF, Whiz
9	110-4079	1	Spring-Compression
12	110-4069	1	Bracket
13	115-2007	1	Rod-Spring
14	92-2762	1	Pin-Hair
15	3231-25	4	Bolt-CARR
16	119-8010-03	1	Kickstand ●
17	107-7400	1	Pin-Lynch
18	110-4058	1	Bracket-Chain
19	107-3258	1	Frame
20	107-2979	6	Bolt-Shoulder
21	3234-19	2	Screw-HHF
22	130-8094	2	Washer-Plain
23	108-4279	2	Spacer-Frame
24	108-4284	1	Tube-Support
25	107-7433	1	Carrier Frame ASM
25:2	93-2877	2	Bushing
26	302-5	1	Fitting-Grease
27	67-9410	1	Washer

● Optional Equipment

■ Not serviced separately



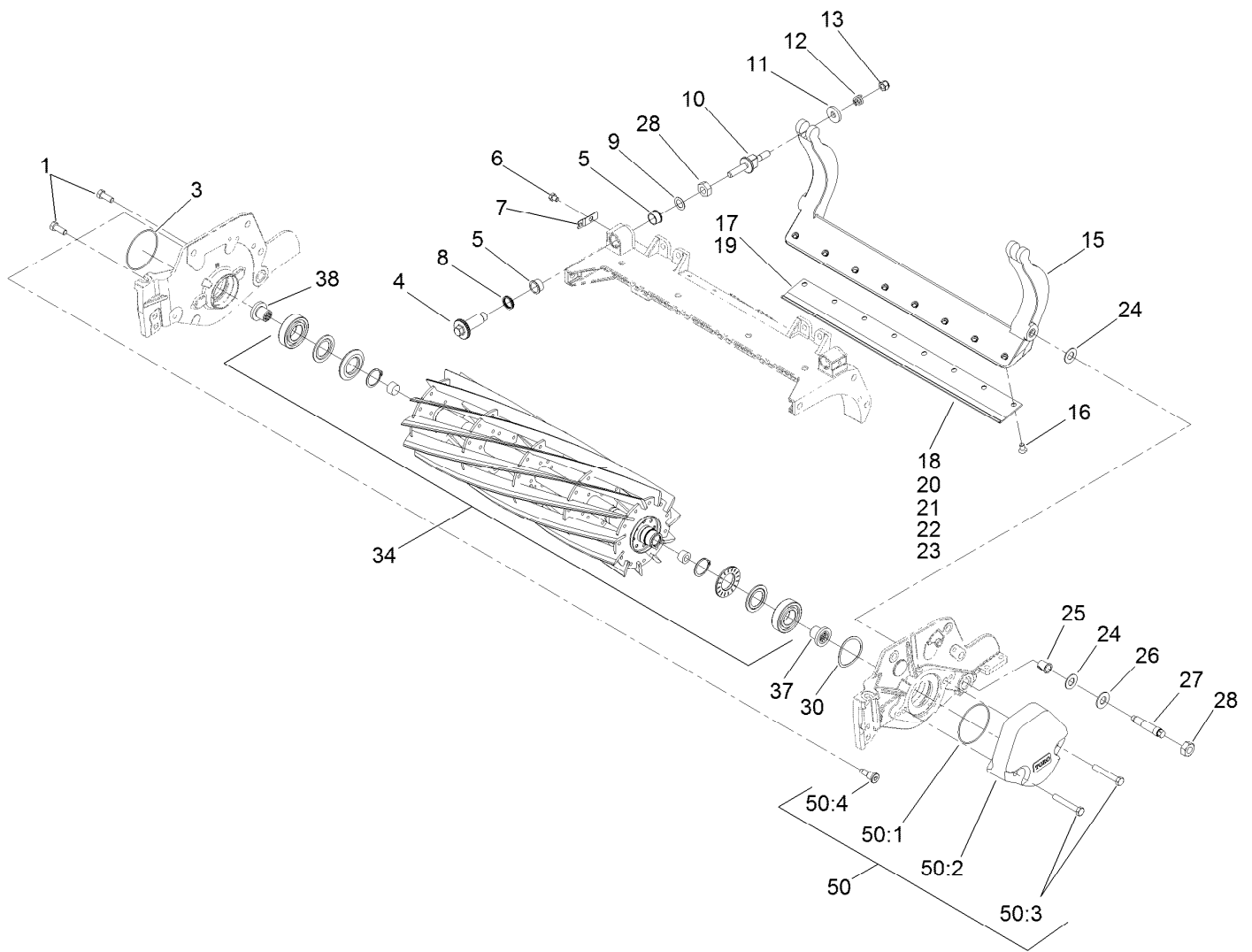

## Reel and Bedbar Assembly (continued)

Ref.	Part Number	Qty.	Description
34	137-8446	1	ES Reel+,7In Fwy(22)8 Bld LD(Fsr)
37	127-7111	1	Insert-Threaded, 7 Inch (LH)
38	127-7109	1	Insert-Threaded, 7 Inch (RH)
45	120-7230	1	HD DPA MVP Kit ●■

Ref.	Part Number	Qty.	Description
50	127-7129	1	Weight Kit ■
50:1	112-6967	5	O-Ring
50:2	108-4269-01	5	Weight
50:3	323-12	10	Screw-HH
50:4	127-7122	5	Bolt-Shoulder, Flange Hex Socket

● Not illustrated

■ Optional Equipment

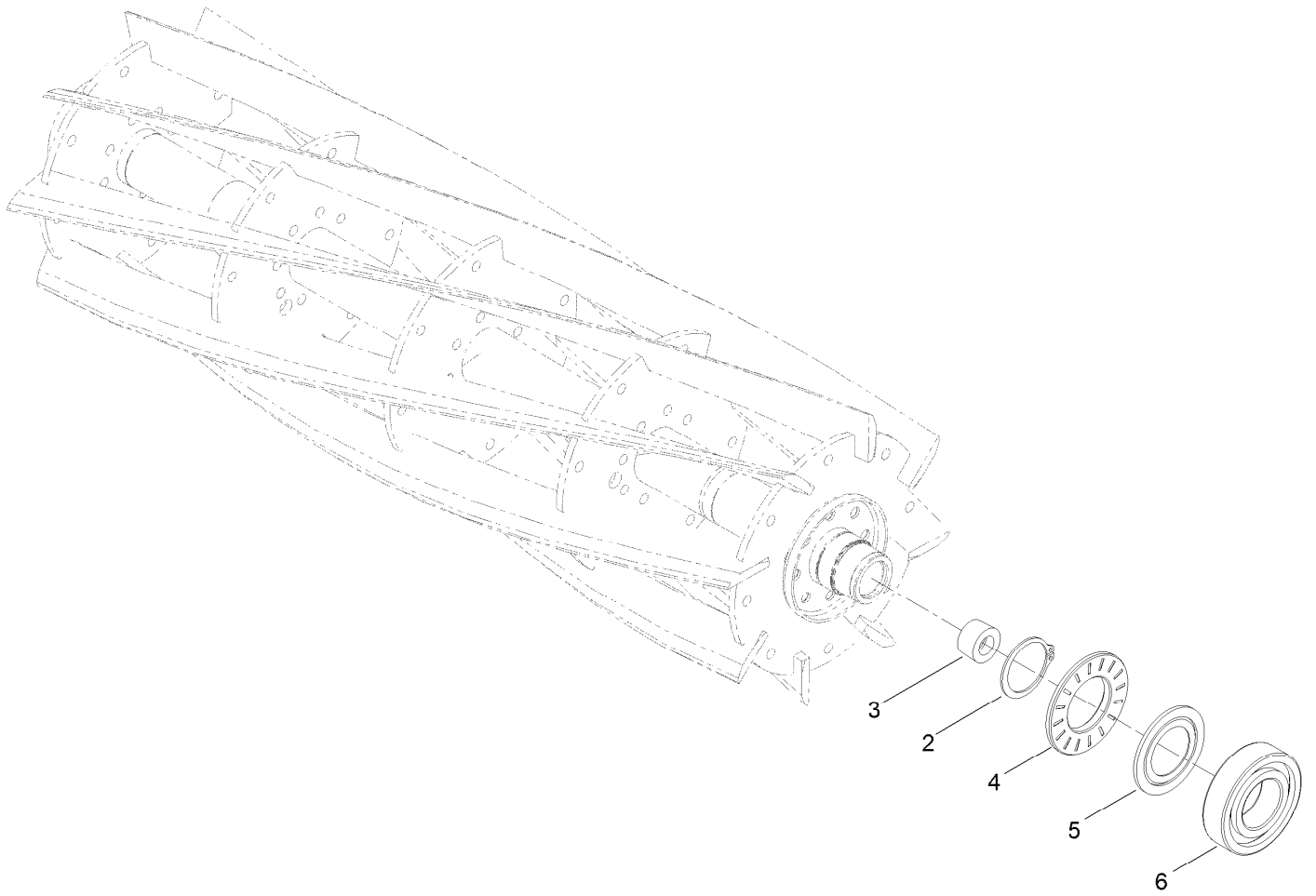

## 7in EdgeSeries+ 22in Fairway, 8 Blade, Low Drag, Forward Swept Reel Assembly No. 137-8446

<i>Ref.</i>	<i>Part Number</i>	<i>Qty.</i>	<i>Description</i>
2	92-2601	2	Ring-Retaining
3	127-7118	2	Plug-Shaft, Reel
4	127-4284	2	Washer-Special
5	115-3299	2	Seal-Flocked
6	115-3296	2	Bearing-Sealed

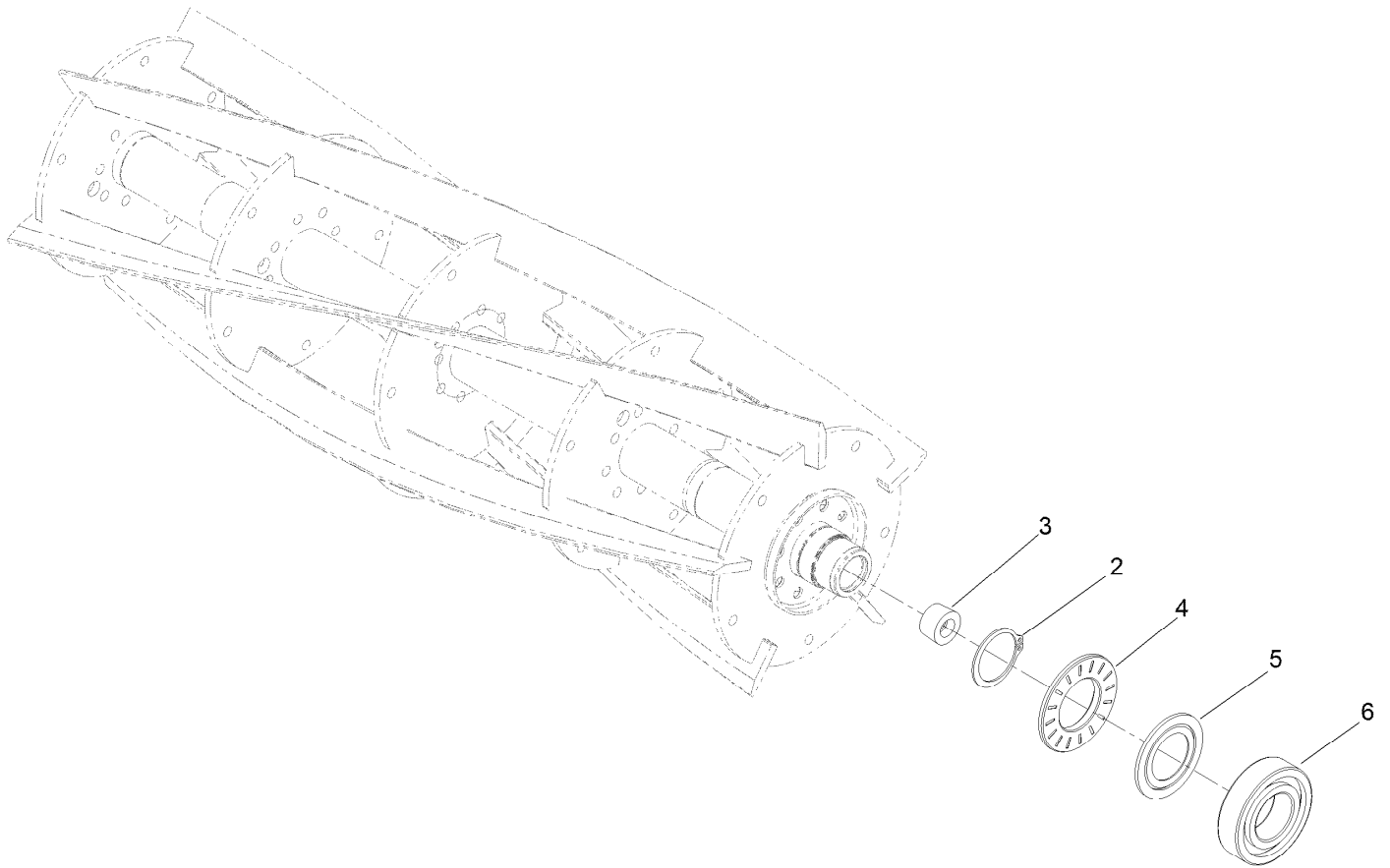

## Optional 7in EdgeSeries+ 22in Fairway, 5 Blade Radial Reel Assembly No. 137-8444

<i>Ref.</i>	<i>Part Number</i>	<i>Qty.</i>	<i>Description</i>
2	92-2601	2	Ring-Retaining
3	127-7118	2	Plug-Shaft, Reel
4	127-4284	2	Washer-Special
5	115-3299	2	Seal-Flocked
6	115-3296	2	Bearing-Sealed



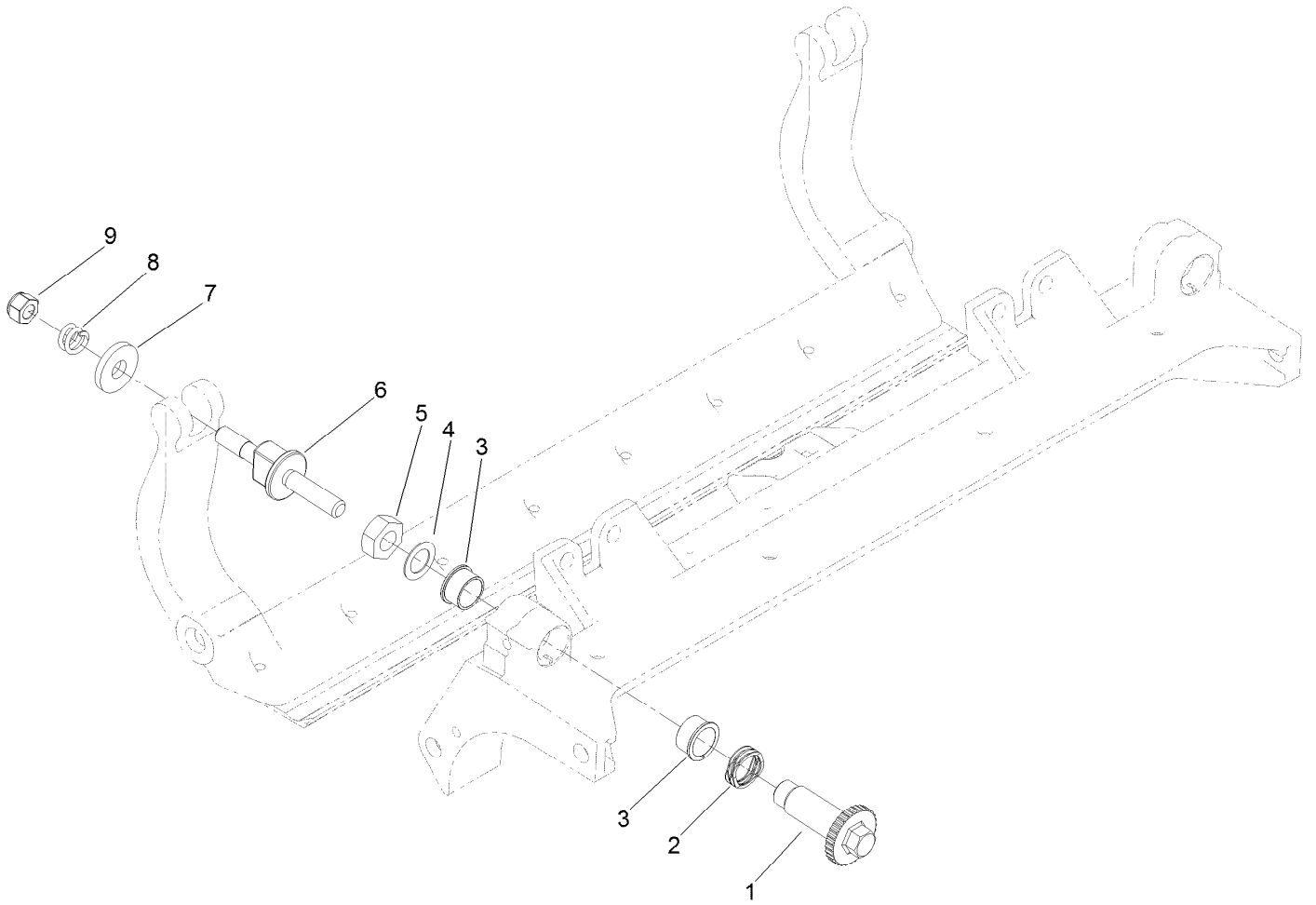

## Optional Heavy-Duty MVP Kit No. 120-7230

<i>Ref.</i>	<i>Part Number</i>	<i>Qty.</i>	<i>Description</i>
1	120-5118	2	Shaft-Adjuster
2	120-5116	2	Washer-Wave
3	106-5344	4	Bushing-Flange, Keyed
4	108-0015	2	Washer-Flat
5	3296-33	2	Nut-Lock, NI
6	137-6130	2	Screw-Adjuster, Bedbar
7	119-4155	2	Washer-Hardened
8	120-5120	2	Spring-Compression
9	119-4039	2	Nut-Hex, NI

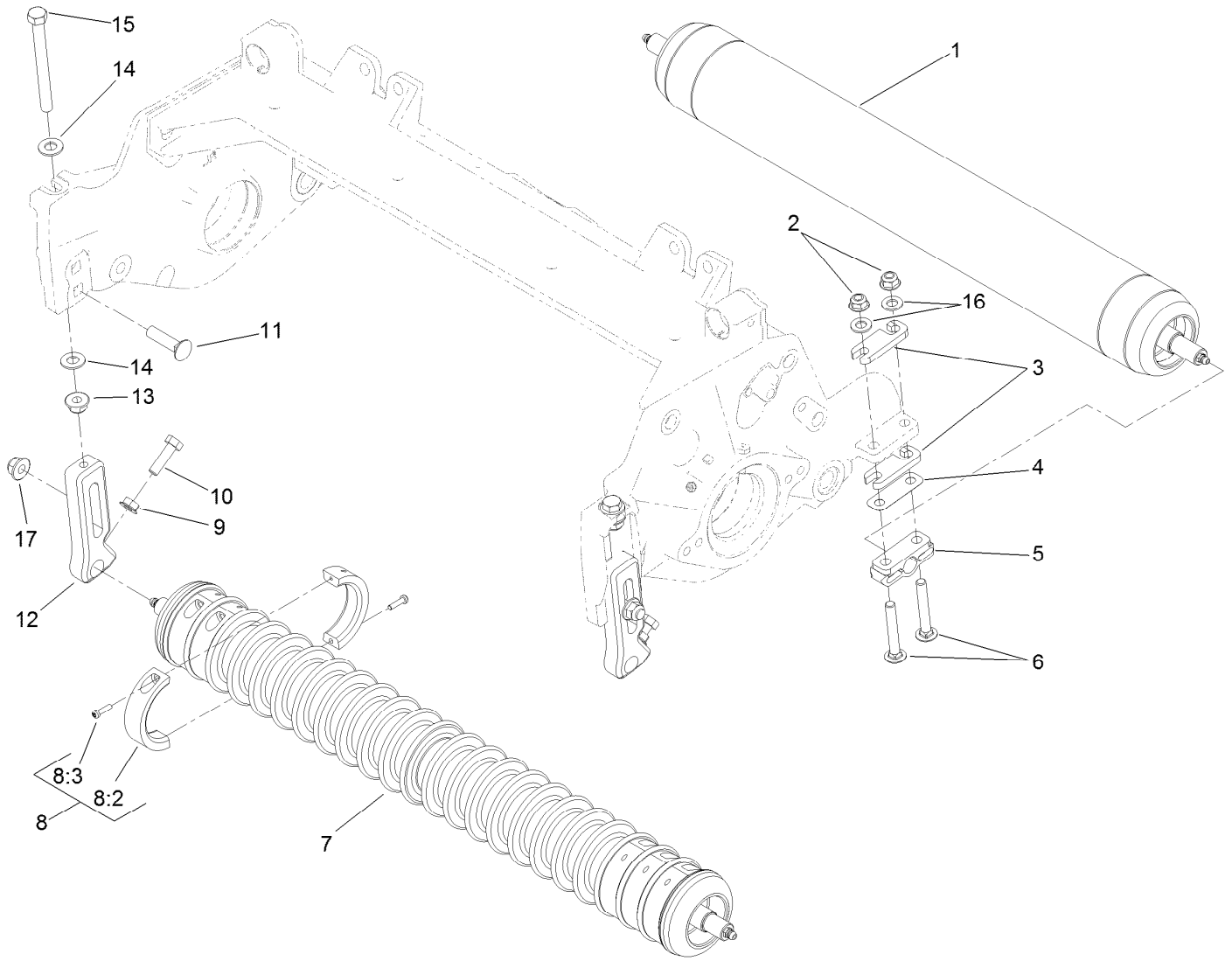

## Roller Assembly

Ref.	Part Number	Qty.	Description	Ref.	Part Number	Qty.	Description
1	114-5415	1	3 Inch DIA Roller ASM (Long)	8	104-8215	6	Collar Kit ■
1	137-6117	1	Short Rear Roller ASM (3In DIA)(22In) ● ■	8:2	100-4959	2	Collar
2	104-8300	4	Nut-HF, NI	8:3	104-1835	2	Screw
3	119-0626	8	Shim-Roller	9	32128-20	2	Nut-HF
4	107-4001	2	Shim-Roller (0.01 Inch) ■	10	322-16	2	Screw-HH
5	106-3924	2	Bracket-Roller, Rear	11	3231-4	2	Screw-CARR
6	3230-26	4	Screw-CARR	12	125-2796	2	Bracket-Front HOC
7	114-5400	1	Plastic Wiehle Roller ASM	13	104-8301	2	Nut-HF, NI
7	114-5421	1	Plastic Shoulder Roller ASM ● ■	14	48-9220	4	Washer-Plain
7	137-6111	1	Full Front Roller ASM (3In DIA)(22In) ● ■	15	133-7571	2	Screw-HOC, Fairway
				16	94-6936	4	Washer-Hardened
				17	133-7570	2	Nut-Flange, NI
				50	137-0890	1	Rm DPA High HOC Kit (F18 & Up) ● ■

● Not illustrated

■ Optional Equipment

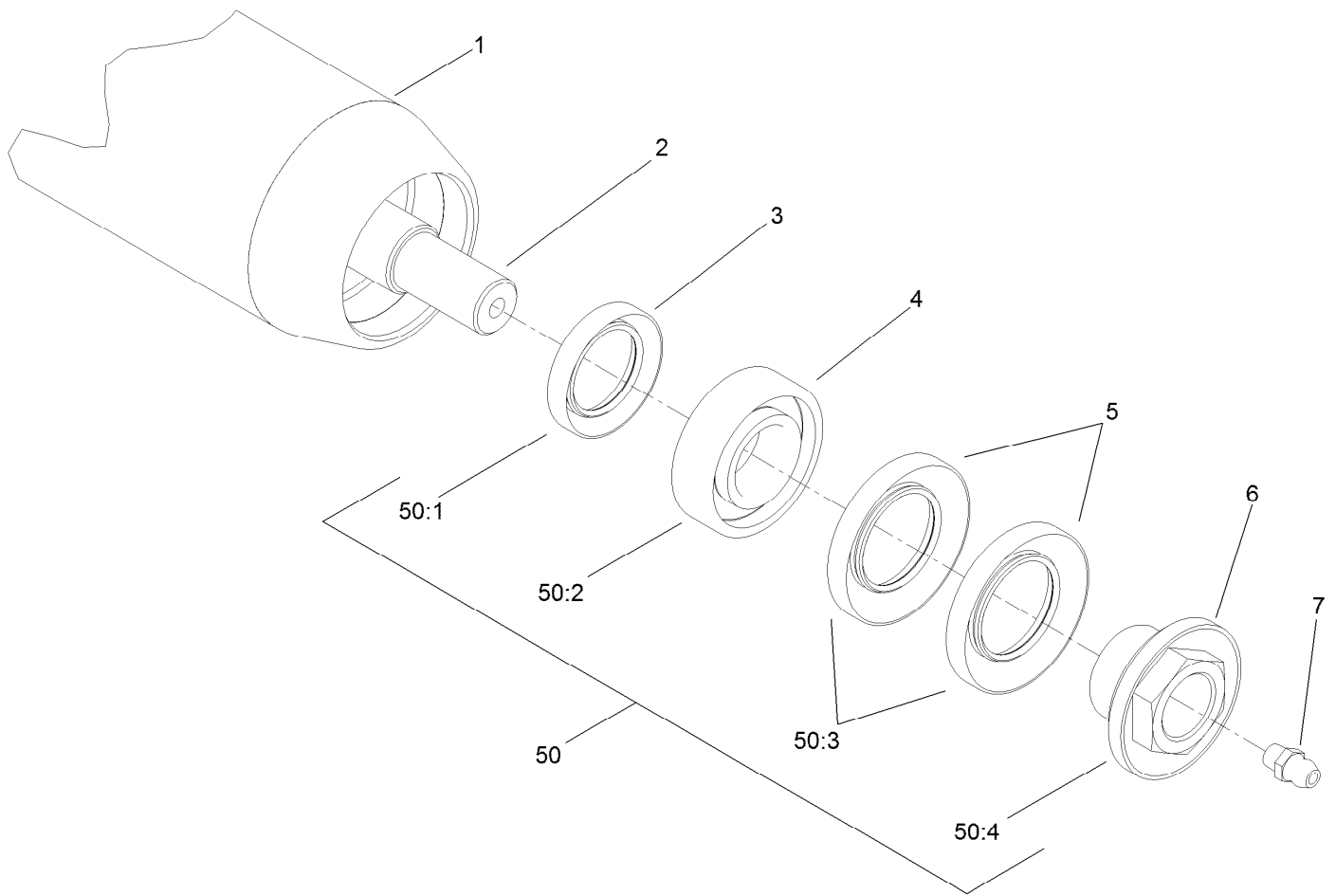

## 3 Inch Diameter Long Roller Assembly No. 114-5415

<i>Ref.</i>	<i>Part Number</i>	<i>Qty.</i>	<i>Description</i>
1	115-8292-0P	1	Tube-Long
2	114-5407	1	Shaft-Long, Rear Roller
3	114-3717	2	Seal-Oil
4	112-5290	2	Bearing-Steel, Stainless
5	112-7494	4	Seal
6	114-5411	2	Nut-Lock, Bearing
7	302-5	2	Fitting-Grease
50	114-5430	1	Rm/Gm Roller Rebuild Kit ●
50:1	114-3717	2	Seal-Oil
50:2	112-5290	2	Bearing-Steel, Stainless
50:3	112-7494	4	Seal
50:4	114-3745	2	Nut-Lock, Bearing

● Optional Equipment

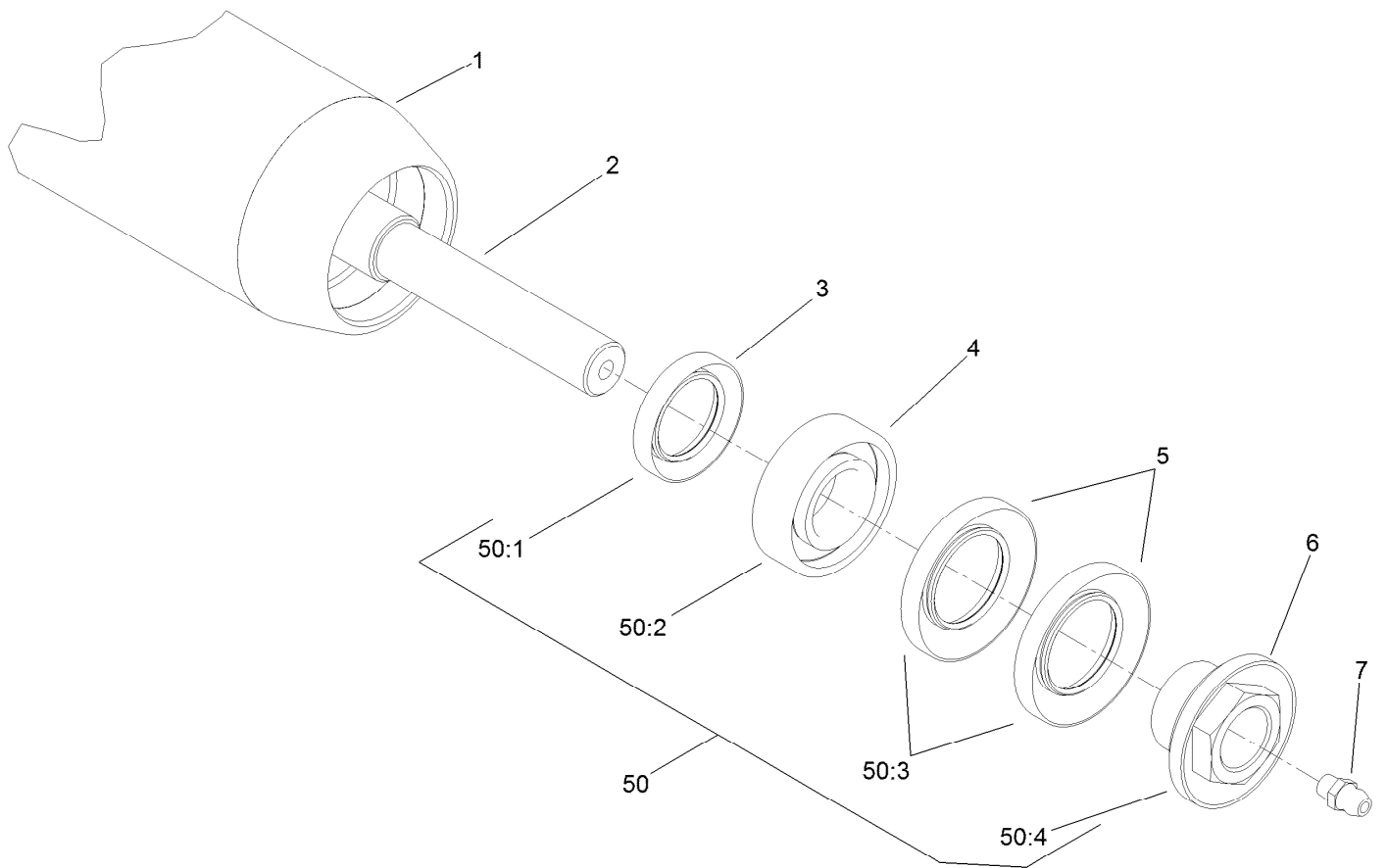

## Optional 3 Inch Diameter Short Roller Assembly No. 137-6117

<i>Ref.</i>	<i>Part Number</i>	<i>Qty.</i>	<i>Description</i>
1	137-6115	1	Tube Roller 3.0In DIA X 20.5In
2	114-5410	1	Shaft-Short, Rear Roller
3	114-3717	2	Seal-Oil
4	112-5290	2	Bearing-Steel, Stainless
5	112-7494	4	Seal
6	114-5411	2	Nut-Lock, Bearing
7	302-5	2	Fitting-Grease
50	114-5430	1	Rm/Gm Roller Rebuild Kit ●
50:1	114-3717	2	Seal-Oil
50:2	112-5290	2	Bearing-Steel, Stainless
50:3	112-7494	4	Seal
50:4	114-3745	2	Nut-Lock, Bearing

● Optional Equipment

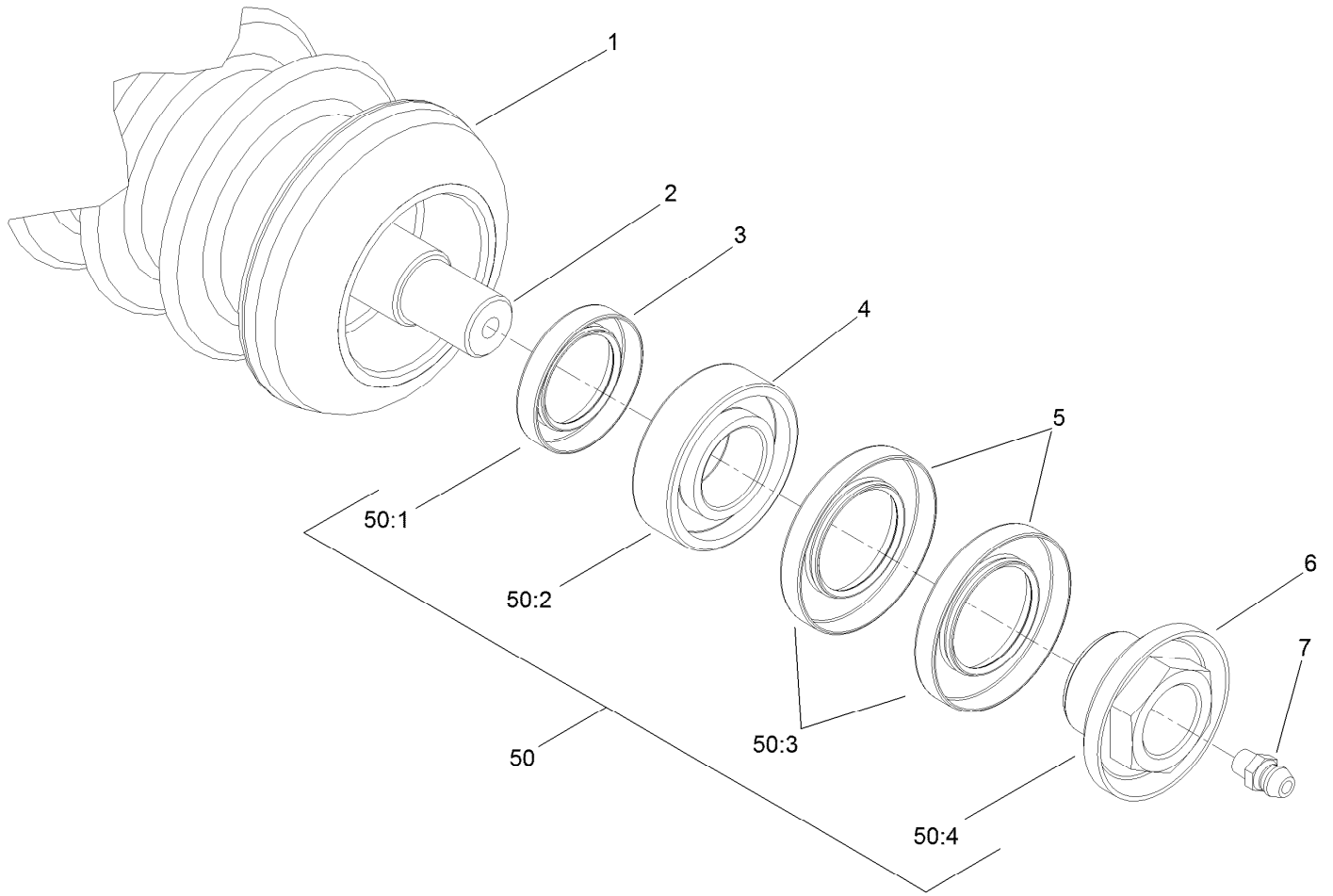

## Plastic Wiehle Roller Assembly No. 114-5400

<i>Ref.</i>	<i>Part Number</i>	<i>Qty.</i>	<i>Description</i>
1	114-5401	1	Wiehle Roller Plastic (22In)
2	114-5403	1	Shaft-Roller, Front
3	114-3717	2	Seal-Oil
4	112-5290	2	Bearing-Steel, Stainless
5	112-7494	4	Seal
6	114-5411	2	Nut-Lock, Bearing
7	302-5	2	Fitting-Grease
50	114-5430	1	Rm/Gm Roller Rebuild Kit ●
50:1	114-3717	2	Seal-Oil
50:2	112-5290	2	Bearing-Steel, Stainless
50:3	112-7494	4	Seal
50:4	114-3745	2	Nut-Lock, Bearing

● Optional Equipment

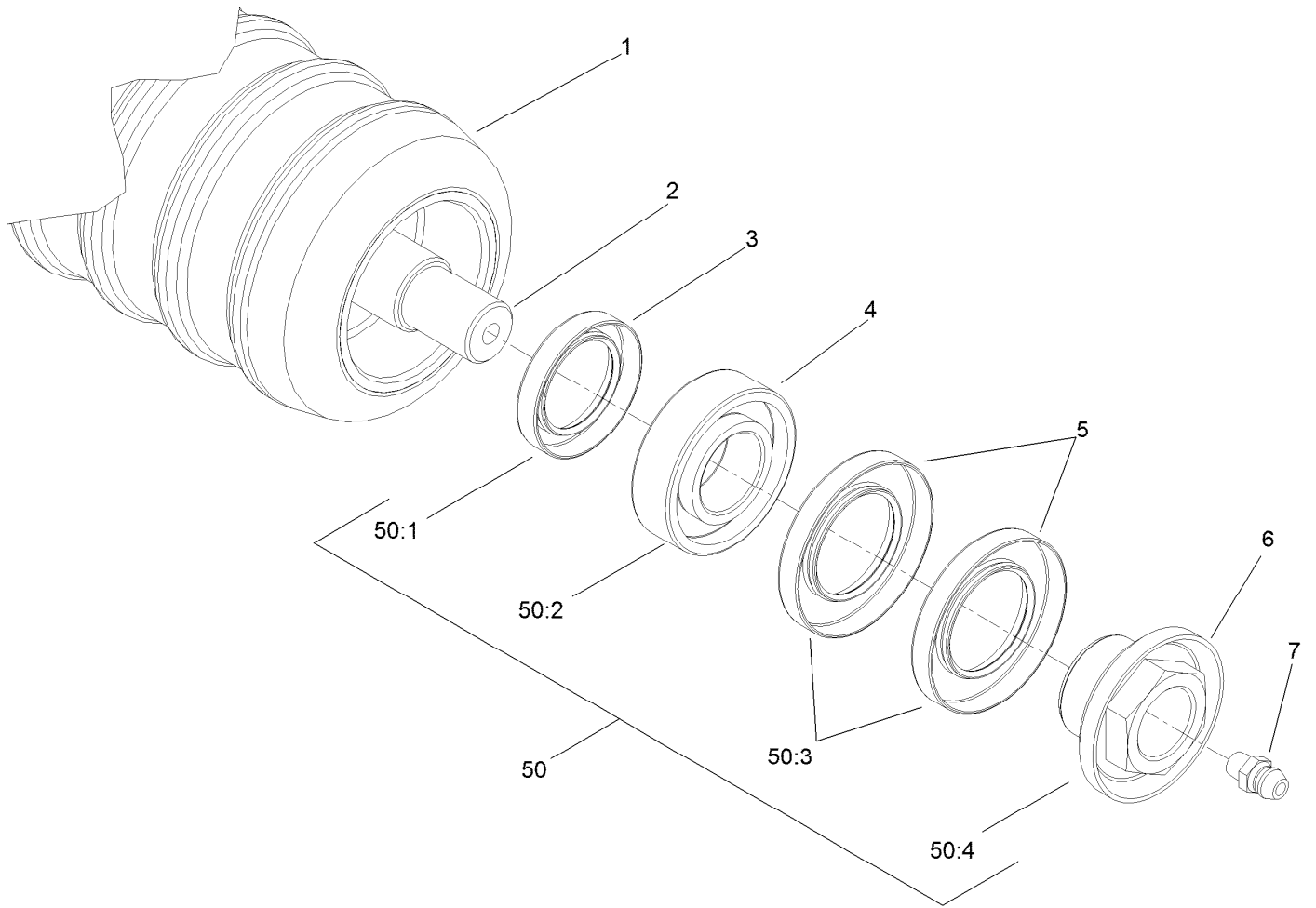

## Optional Plastic Shoulder Roller Assembly No. 114-5421

<i>Ref.</i>	<i>Part Number</i>	<i>Qty.</i>	<i>Description</i>
1	114-5422	1	Roller-Shoulder, Plastic
2	114-5403	1	Shaft-Roller, Front
3	114-3717	2	Seal-Oil
4	112-5290	2	Bearing-Steel, Stainless
5	112-7494	4	Seal
6	114-5411	2	Nut-Lock, Bearing
7	302-5	2	Fitting-Grease
50	114-5430	1	Rm/Gm Roller Rebuild Kit ●
50:1	114-3717	2	Seal-Oil
50:2	112-5290	2	Bearing-Steel, Stainless
50:3	112-7494	4	Seal
50:4	114-3745	2	Nut-Lock, Bearing

● Optional Equipment

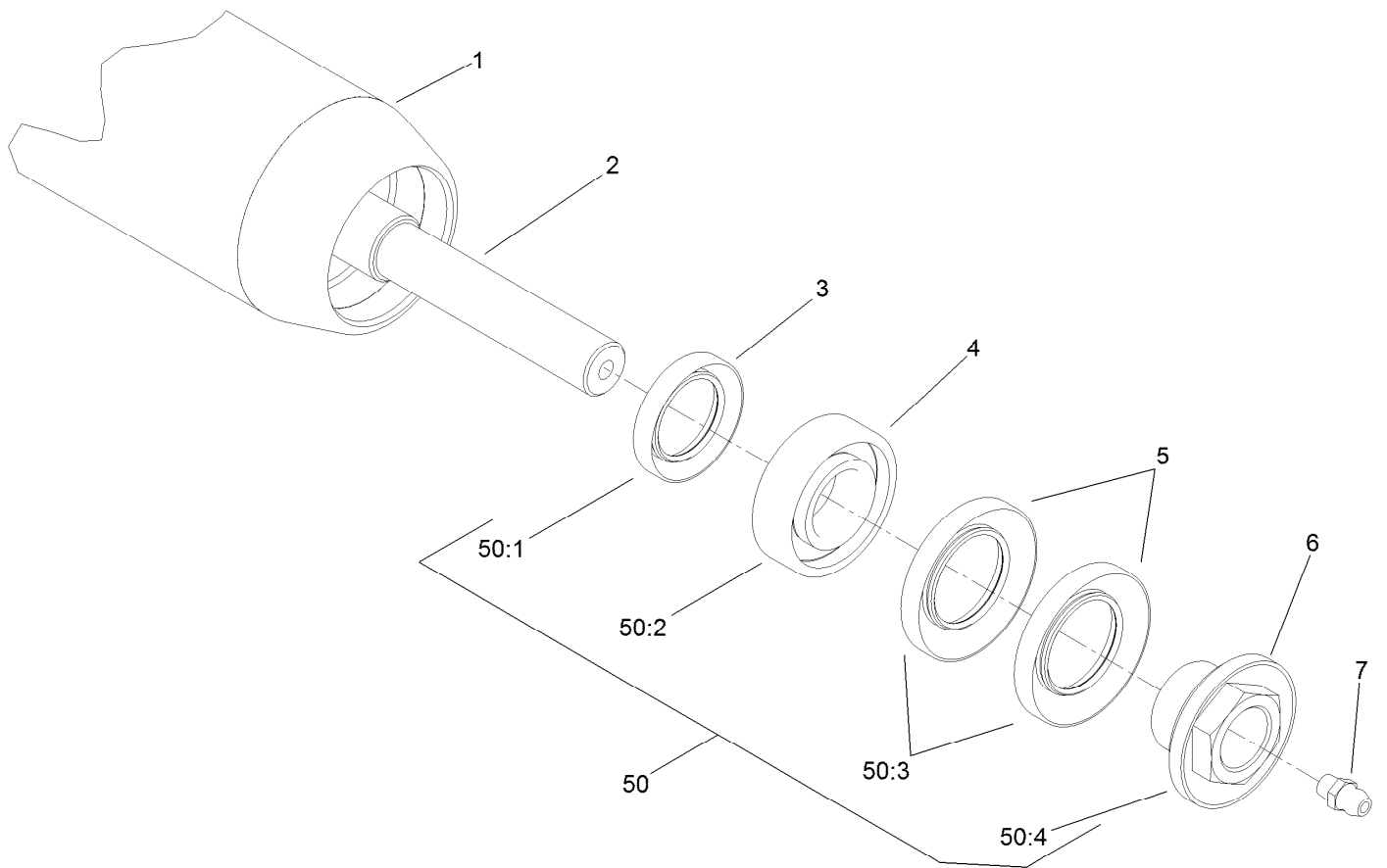

## Optional Full Front Roller Assembly No. 137-6111

<i>Ref.</i>	<i>Part Number</i>	<i>Qty.</i>	<i>Description</i>
1	137-6110	1	Tube Roller 3.0In DIA X 24.5In
2	114-5403	1	Shaft-Roller, Front
3	114-3717	2	Seal-Oil
4	112-5290	2	Bearing-Steel, Stainless
5	112-7494	4	Seal
6	114-5411	2	Nut-Lock, Bearing
7	302-5	2	Fitting-Grease
50	114-5430	1	Rm/Gm Roller Rebuild Kit ●
50:1	114-3717	2	Seal-Oil
50:2	112-5290	2	Bearing-Steel, Stainless
50:3	112-7494	4	Seal
50:4	114-3745	2	Nut-Lock, Bearing

● Optional Equipment

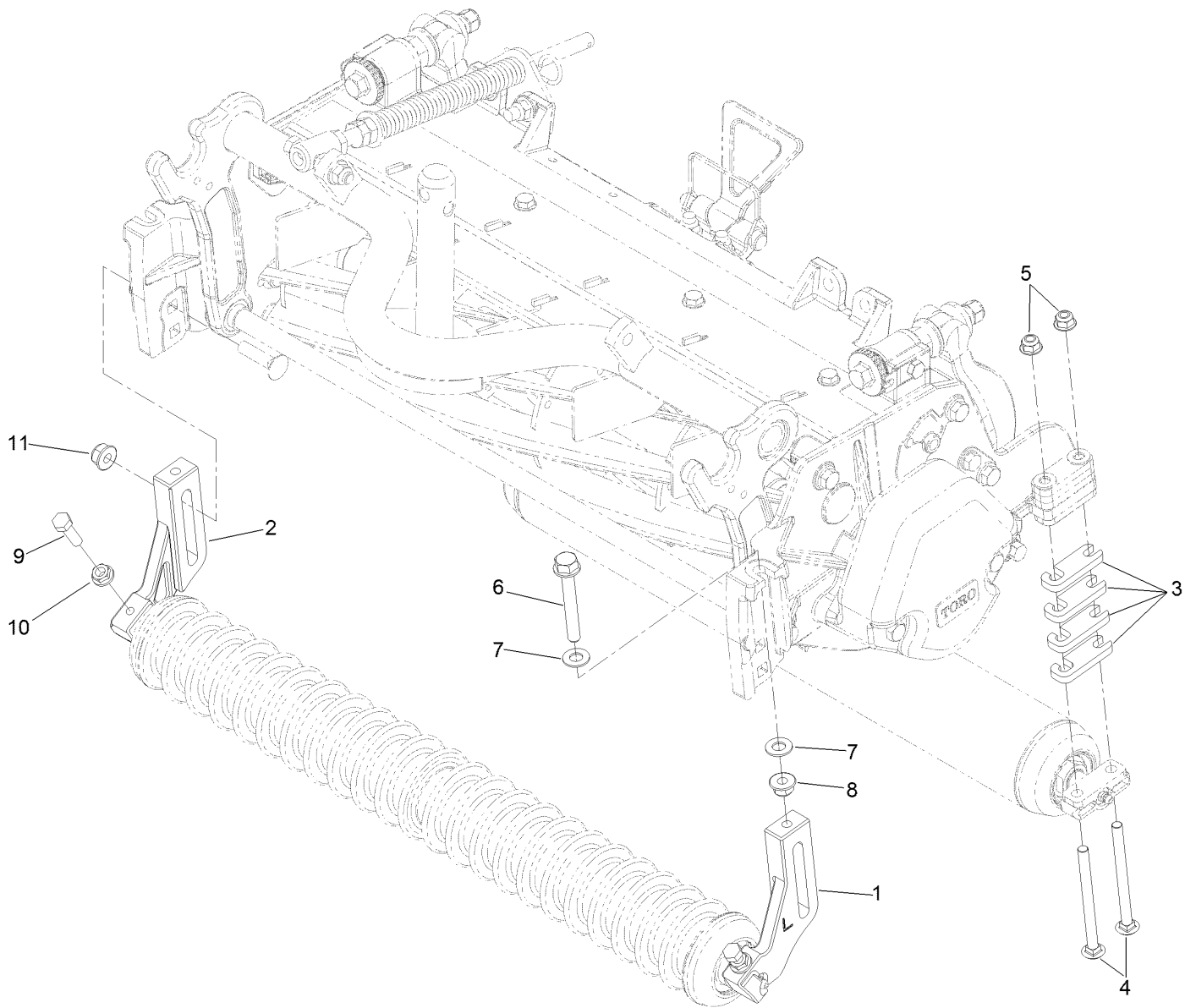

## Optional High Height-of-Cut Assembly No. 137-0890

<i>Ref.</i>	<i>Part Number</i>	<i>Qty.</i>	<i>Description</i>
1	120-0404	1	Bracket-High HOC (LH)
2	120-0405	1	Bracket-High HOC (RH)
3	119-0626	8	Shim-Roller
4	106-9758	4	Screw-CARR
4	3230-30	4	Screw-CARR
5	104-8300	4	Nut-HF, NI
6	133-7572	2	Screw-HOC
7	48-9220	4	Washer-Plain
8	104-8301	4	Nut-HF, NI
9	322-16	2	Screw-HH
10	32128-20	2	Nut-HF
11	133-7570	2	Nut-Flange, NI



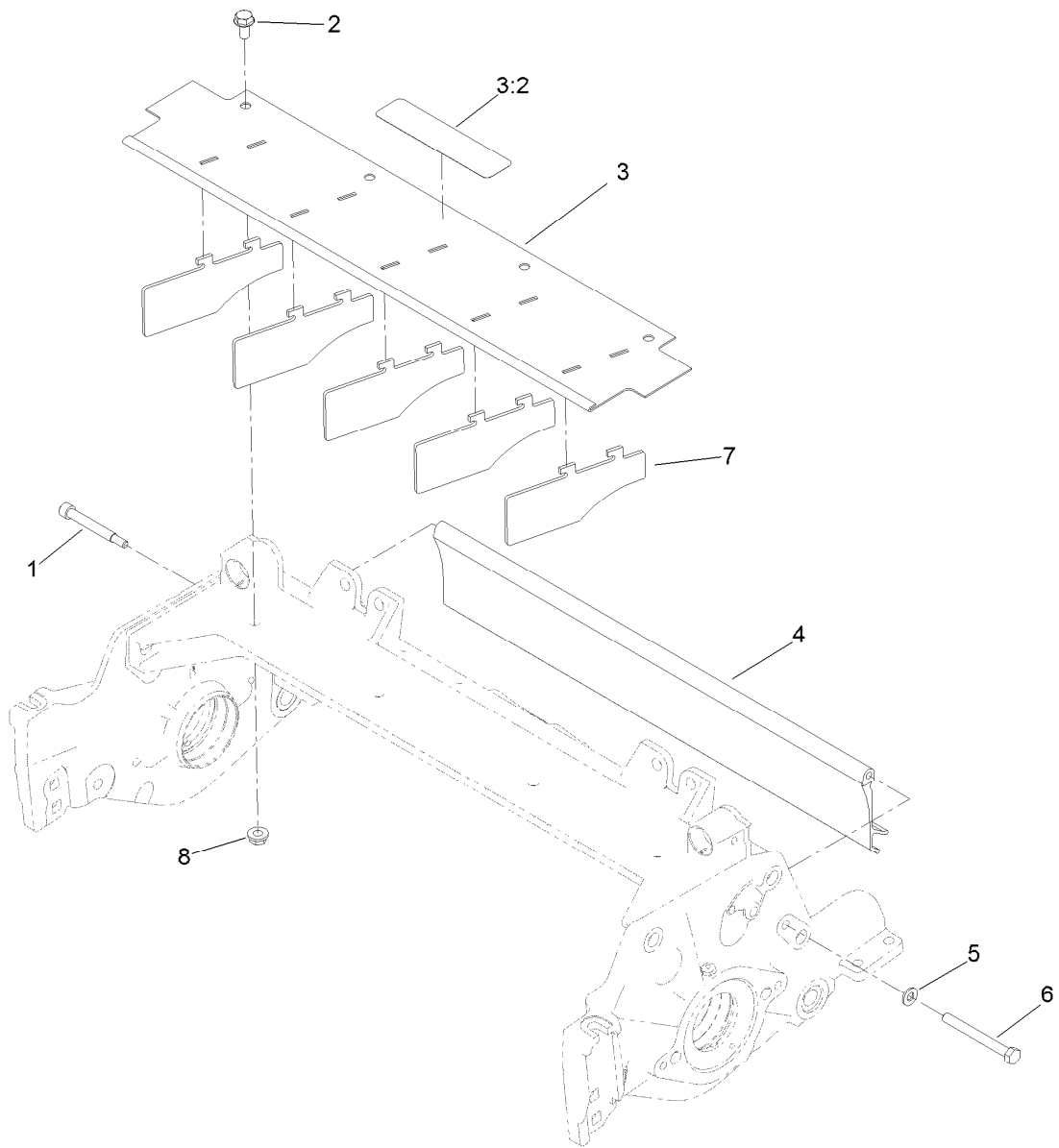

## Shield Assembly

Ref.	Part Number	Qty.	Description
1	107-7773	1	Screw-HSH
2	3234-7	4	Screw-HHF
3	107-2996	1	Front Glass Shield ASM
3:2	137-9706	1	Decal-Warning
4	125-1978	1	Shield-Glass, Rear
5	3256-74	1	Washer-Flat
6	322-14	1	Screw-HH
7	110-1706	5	Deflector
8	32128-20	4	Nut-HF

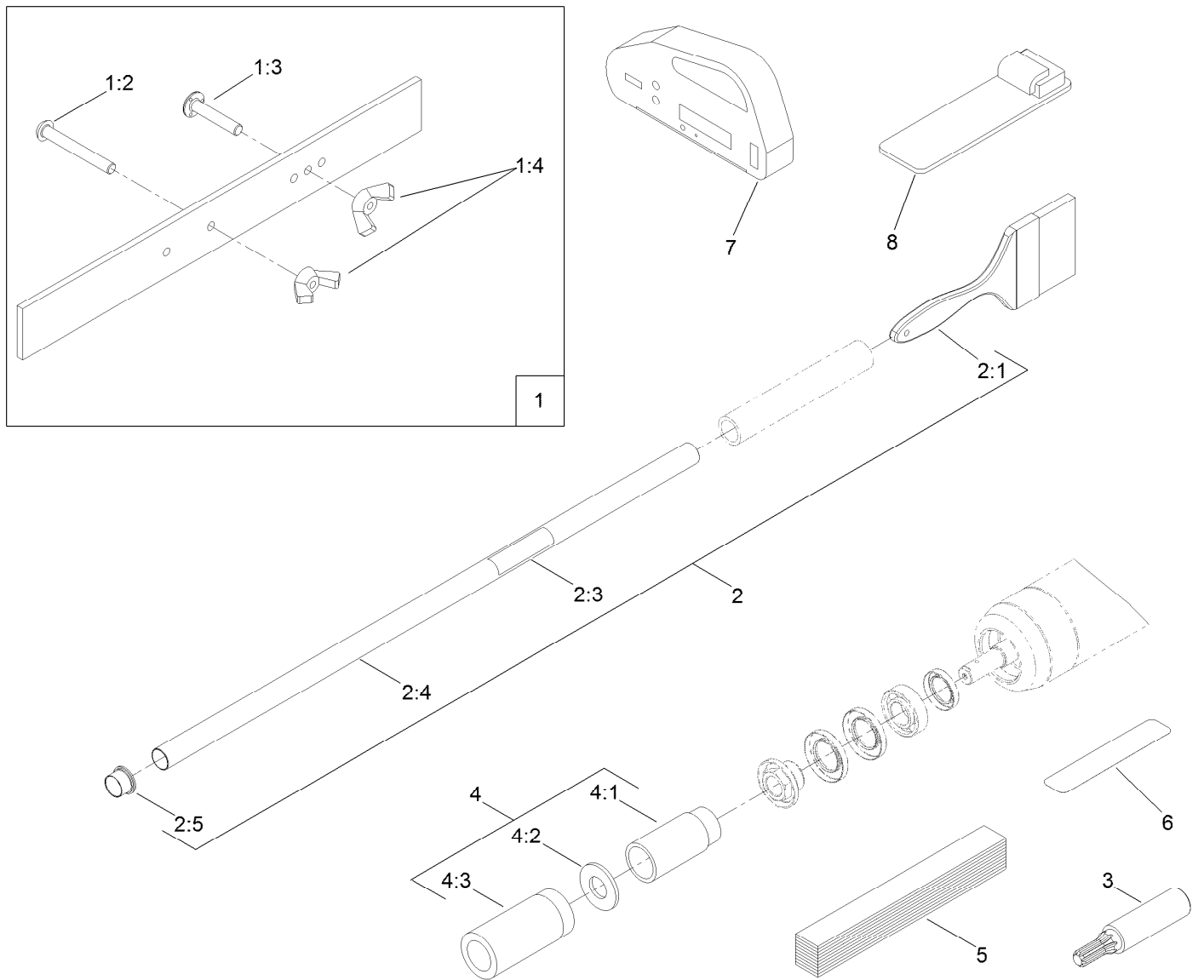

## Optional Tool Assembly

Ref.	Part Number	Qty.	Description	Ref.	Part Number	Qty.	Description
1	108-6715	1	Gauge Bar ASM	4:1	115-0852	1	Tool-Inner Seal
1:2	32122-54	1	Screw-Head, Truss	4:2	107-8133	1	Washer-Flat
1:3	108-6714	1	Stud-Weld	4:3	115-0853	1	Tool-Bearing/Outer Seal
1:4	32103-3	2	Nut-Wing	5	125-5610	1	Paper-Reel, Toro (10 Pack)
2	29-9100	1	Brush And Handle ASM	6	125-5611	1	Shim-Reel, Toro (0.002 Inch)
2:1	36-4310	1	Brush	7	131-6828	1	Indicator-Angle
2:3	98-3206	1	Decal	8	131-6829	1	Mount-Indicator, Angle
2:4	29-9080	1	Handle	9	137-0924	1	Tool-Hand TAP 7/8-16 (Rm DPA Reel) ●
2:5	2410-18	1	Cap-Plastic	10	137-0925	1	Tool-Hand TAP 7/8-16, LH (Rm DPA Reel) ●
3	TOR4074	1	Adapter-Drive, Reel ■				
4	115-0803	1	Rm/Gm Roller Rebuild Tool Kit				

● Not illustrated

■ Obtain directly from K-Line Industries, Inc. (<https://klineind.com>)

# Attachments and Accessories

## For 03639 8-Blade EdgeSeries Forward Swept Reel DPA Cutting Unit with 7in Reel Reelmaster 5010 Series Traction Unit

Product Name	Model/Part
Verticutter for 7in Reel Cutting Unit.....	03619
Groomer Rod Kit.....	131-6845
Rear Roller Brush Kit (7in Reel).....	03408
Weight Kit for 8-Blade or 11-Blade DPA Cutting Unit with 7in Reel Traction Unit.....	03405
Rear Lift Cylinder Limit Kit .....	110-9604
Rear Roller Scraper Kit.....	107-3280
Wiehle Scraper ASM .....	107-2993-03
Comb/Scraper Kit .....	110-1735
Angle Indicator.....	131-6828
Angle Indicator Mount.....	131-6829
Full Front Roller Asm (3in Dia)(22in).....	137-6111
3in Full Front Roller Scraper .....	110-9602-03
Plastic Shoulder Roller ASM.....	114-5421
Shoulder Roller Scraper ASM.....	110-9609-03
High Height-of-Cut Kit, Reelmaster 3000 or 5000 Series DPA Cutting Unit .....	137-0890
3in Dia Collar Kit .....	104-8215
Cutting Unit Kickstand .....	119-8010-03
Reel Drive Adapter .....	TOR4074
Roller Rebuild Tool Kit.....	115-0803
22in Fairway Flex Grass Basket Kit .....	03415
22in Fairway Compact Grass Basket Kit.....	03416
Brush-Roller (High Height-Of-Cut).....	110-1740
22in Rear Roller HD Brush .....	137-0842
Gauge Bar Assembly.....	108-6715
Roller Rebuild Kit.....	114-5430
Groomer/RRB Seal Kit.....	131-3233
Heavy-Duty DPA MVP Kit.....	120-7230
Rear Roller Adjustment Kit.....	125-0570
Bedbar-Aggressive, 7in .....	131-3221-0P
Bedknife-Edgemax (Fairway) .....	137-0833
Bedknife-STD (Fairway) .....	108-9096
Bedknife-Edgemax Lowcut.....	137-0832
Bedknife-Low HOC (Fairway) .....	110-4084
Bedknife Edgemax Low cut Extended (Fairway).....	119-4280
Bedknife-Lowcut Extended (Fairway) .....	120-1640
Bedknife-HD (Fairway) .....	110-4074
EdgeSeries+ Reel 7in Fairway(22in) 5 Blade Low Drag(Radial Reel) .....	137-8444
EdgeSeries+ Reel, 7in Fairway(22in) 8 Blade Low Drag(Forward Swept Reel).....	137-8446
Universal Groomer Drive Kit .....	03768
Universal Groomer Cartridge, Reelmaster 3555, 3575, 5010, and 5010-H Series 22-inch EdgeSeries Cutting Units with Universal Groomer .....	03772
Grooming Brush (22In) .....	03767
Broomer Kit (22In) .....	132-7125
Rear Roller Brush Kit for Units with 7in Reel and Universal Groomer (22in) .....	03659

## Attachments and Accessories (continued)

Weight Kit for Units with 5 Inch Electric Reel or 7 Inch Electric or Hydraulic Reel and Universal Groomer Only .....	03418
Weight Kit for Units with 5 Inch Electric Reel or 7 Inch Electric or Hydraulic Reel and Universal Groomer with Rear Roller Brush .....	03419
Universal Groomer Drive MVP Kit, Reelmaster 3575, 5010, and 5010-H Series 22-inch Cutting Units with 7 Inch Reel .....	133-0151
Rear Roller Brush MVP Kit, Reelmaster 5010-H Series 22-inch Cutting Unit with 7-inch Reel and Universal Groomer .....	133-0154
Rear Roller Brush MVP Kit, Reelmaster 5010-H Series Cutting Unit with 7 Inch Reel .....	133-0158
LH 7in Heavy Duty Low Drag Side Plate ASM .....	137-5982
RH 7in Heavy Duty Low Drag Side Plate ASM .....	137-5983
Tool-hand Tap 7/8-16 (RM DPA Reel) .....	137-0924
Tool-hand Tap 7/8-16, LH (RM DPA Reel).....	137-0925
Toro Reel Paper (10 Pack).....	125-5610
Toro Reel Shim (0.002in) .....	125-5611

**Notes:**

**Notes:**

**Notes:**



**Count on it.**