

LH52

Small Diameter Mower Unit

Parts catalog

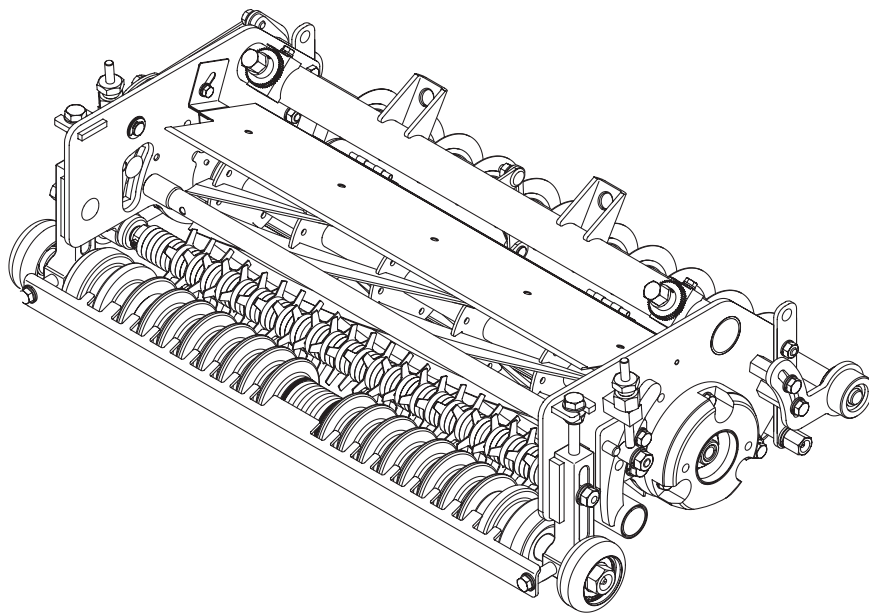

BARONESS
Quality on Demand

Greetings

Thank you for purchasing Baroness product.

This brochure contains the information needed for ordering BARONESS parts.

Search the number indicating the figure of your desired part in the illustration area, and find the same number from among the latter parts of the hyphenated Cat Nos. in the listing area to obtain the individual Code No.

Notes

1) For inquiries of parts

Inform us of the model and the serial number of your machine or attachment.

The model and the serial number are indicated on the serial number plate of your machine or attachment.

* Consult the Owner's Operating Manual for the position where the serial number plate is affixed.

2) For ordering parts

- Inform us of the Code No., Part name and order quantity.
- We do not accept returns unless our company is responsible for the issue.
- Use genuine Baroness parts and accessories. The Baroness product warranty may not apply if parts or accessories from other companies are used.

3) The information described in this brochure is subject to change without prior notice.

Description of the content of Parts catalog

1) Illustration area

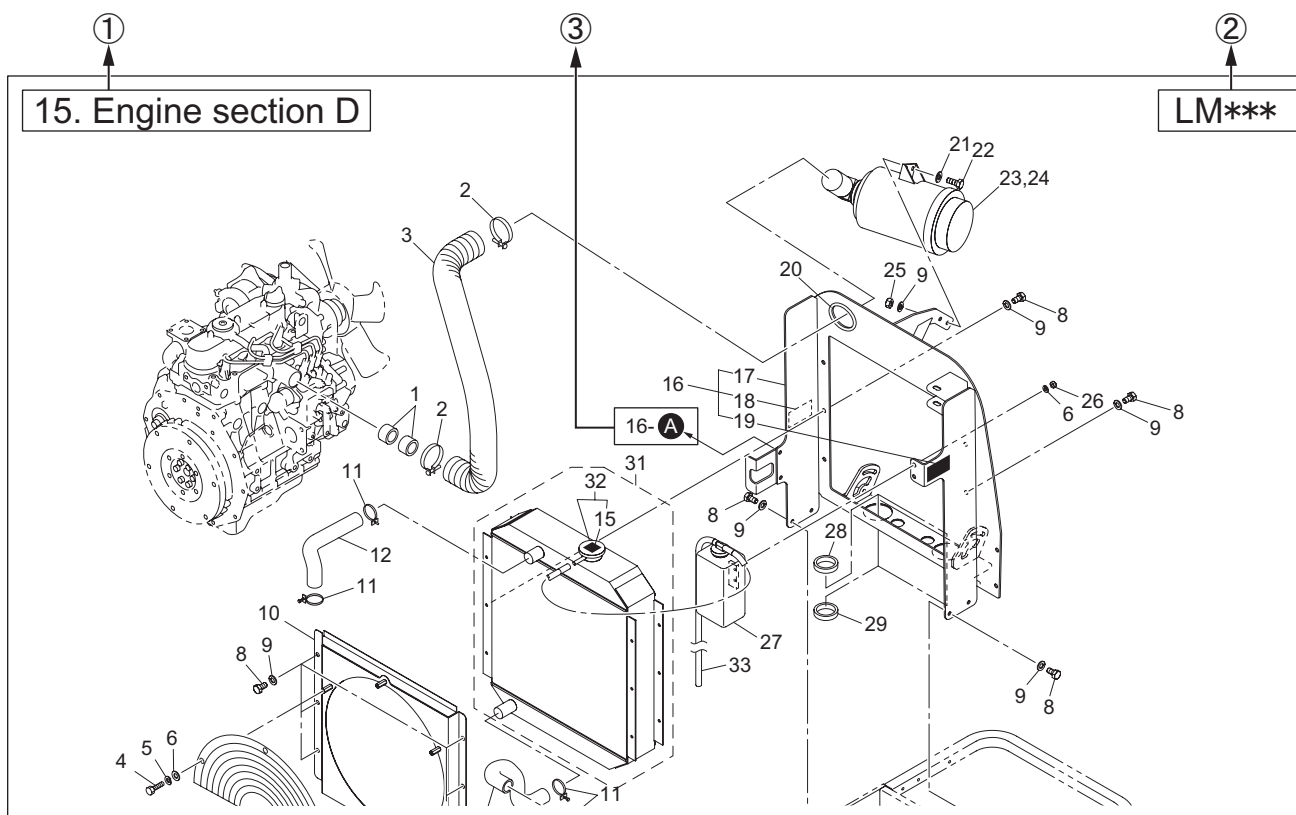

- ① Section No. /Section name
- ② Model
- ③ Indication of the connecting point

The following indication shows the connecting point of the part shown on the other page.

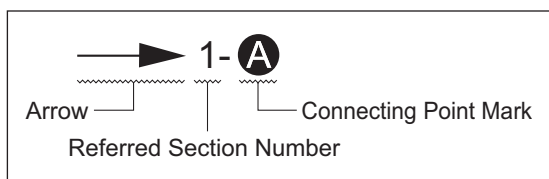

- 1- **A** :
Refer to the point **A** in the illustration of the section No.1
- 2- **B** :
Refer to the point **B** in the illustration of the section No.2

Note :

The figures of assembled components or isolated parts do not always show their accurate shapes. The figures are supposed to be used for obtaining the correct code numbers.

2) Listing area

① Cat No.	② Code No.	③ Part name	④ ⑤ Qty			⑥ Remark	⑦ SN of application
1 - 1	K0000080152	BOLT, M8-15	2	2	2		
1 - 2	K0185160002	NUT, LEFT-HANDED P1.5 M16-3	2	2	2		
1 - 3	K3650000100	HOUR METER, HH2AS	1	1	1		10001-10023
1a- 3	K3650000130	HOUR METER, 636DC	1	1	1		10024-
1 - 4	K0100060002	NUT, M6	2	2	2		
1 - 5	K0003080702	BOLT, M8-70	1	1	1		
1 - 7	K0830000020	OIL SEAL, 254210	2	2	2		

① Cat No. or Catalog No.

Find the same number as the number indicating the figure of your desired part in the illustration area from among the latter parts of the hyphenated Cat Nos. to obtain the individual Code No.

② Code No.

Identification code of an individual part

③ Part name

④ Qty

Quantity needed per Cat No.

⑤ Model

When the quantity differs by models, the models are indicated.

⑥ Remark

Specification or description, etc. of the part may be indicated.

⑦ SN of application

In case of part alteration, the serial number ranges of machines to which the alteration is applied will be indicated.

3) Indication in case of part alteration

- When a new part and an old one are interchangeable with each other, indication of the old part code No. is discontinued and the new part code No. is solely indicated.
- When a new part and an old one are not interchangeable, the serial number ranges of both machines where the new part is used and those where the old one is used are indicated in the SN of application column.
- When a part is newly added, the serial number range of machines where the part is used is indicated in the SN of application column.
- When a part was previously used but the part is not used in the machine any longer, the serial number range of machines where the part was used is indicated in the SN of application column.

Contents

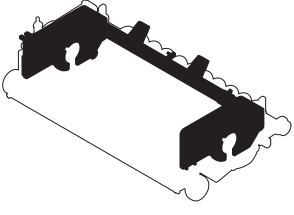
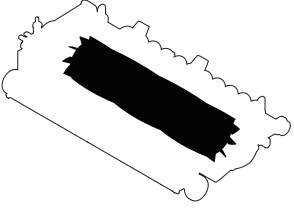
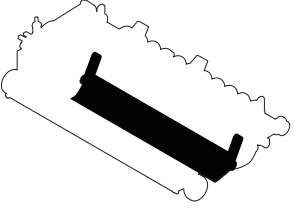
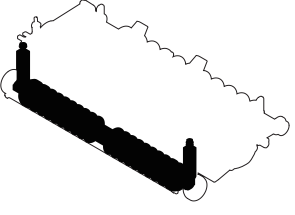
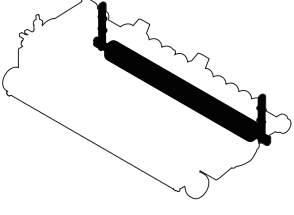
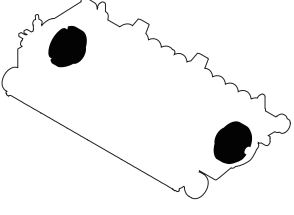
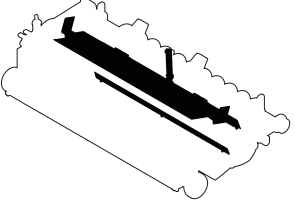
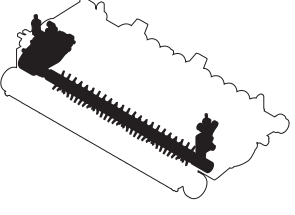
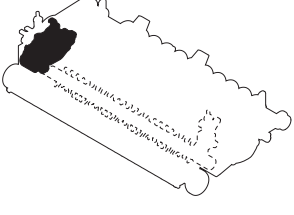
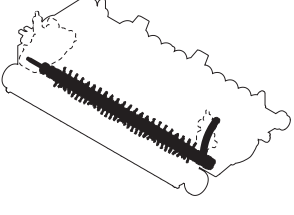
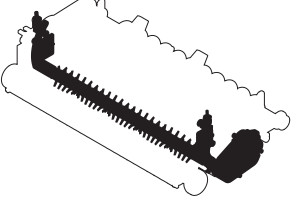
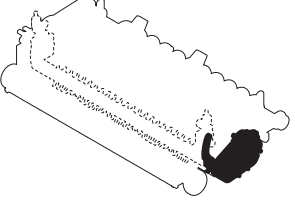
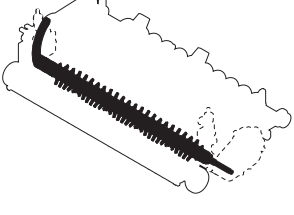
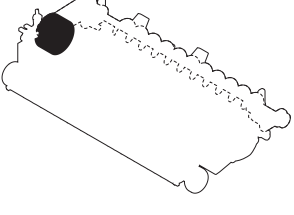
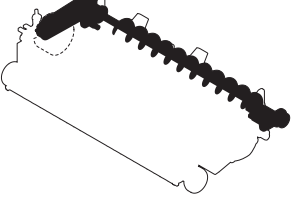
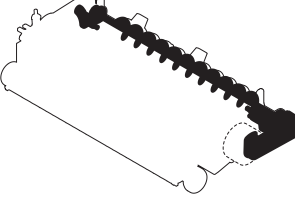
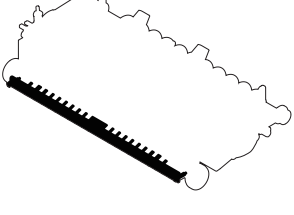
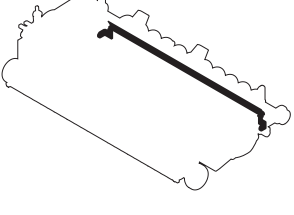
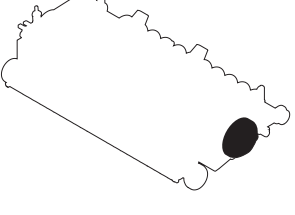
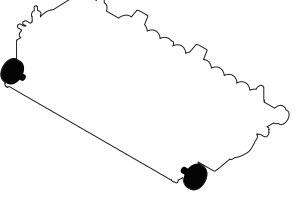
<p>1.Frame section.....3</p> 	<p>2.Reel cutter section.....4</p> 	<p>3.Bed knife section5</p> 	<p>4.Front roller section.....6</p> 
<p>5.Rear roller section7</p> 	<p>6.Housing section8</p> 	<p>7.Reel cover section9</p> 	<p>8.Groomer section A (motor on left side).....10</p> 
<p>9.Groomer section B (motor on left side).....11</p> 	<p>10.Groomer section C (motor on left side).....13</p> 	<p>11.Groomer section D (motor on right side)14</p> 	<p>12.Groomer section E (motor on right side)15</p> 
<p>13.Groomer section F (motor on right side)17</p> 	<p>14.CR brush section A (motor on left side, right side)18</p> 	<p>15.CR brush section B (motor on left side).....19</p> 	<p>16.CR brush section C (motor on right side)21</p> 
<p>17.Front scraper section.....23</p> 	<p>18.Rear scraper section24</p> 	<p>19.Weight section25</p> 	<p>20.Support roller section.....26</p> 

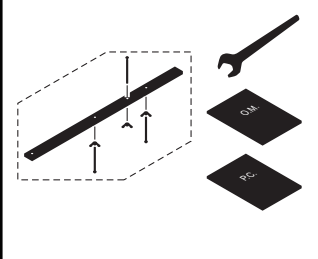

1.Frame section

LH52

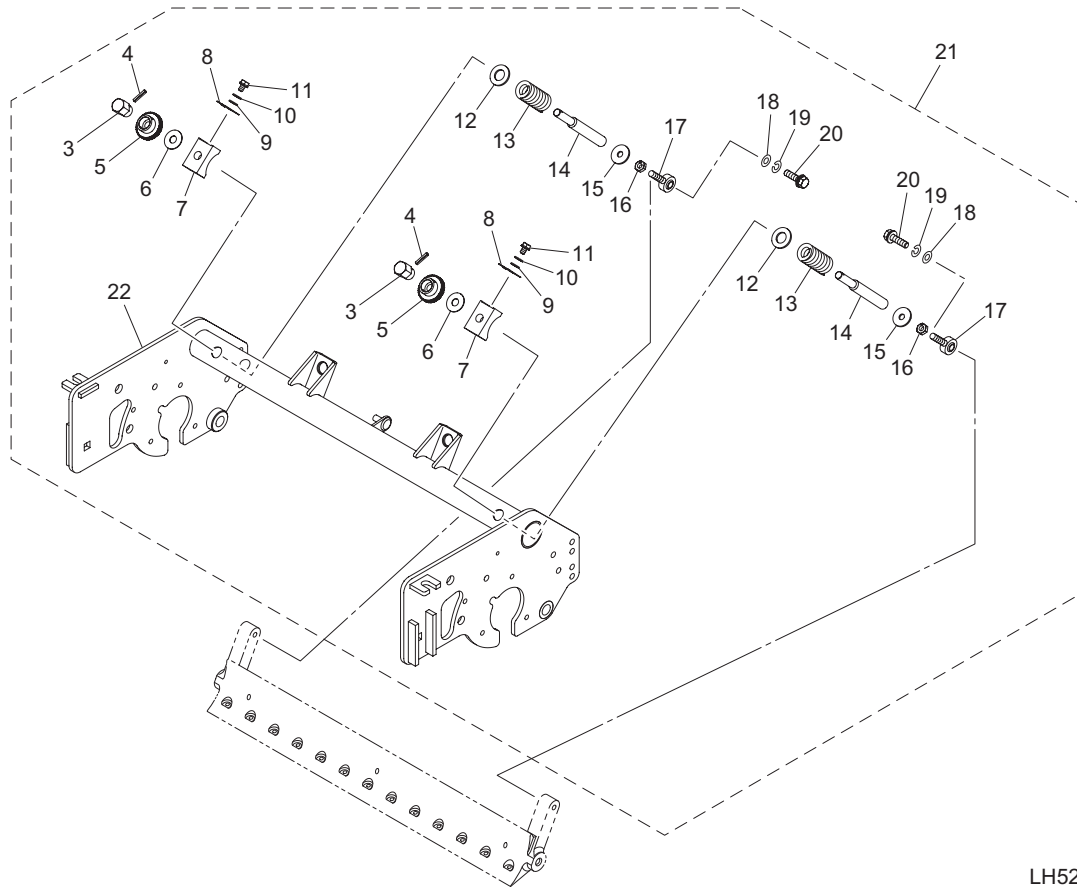

LH52_001_z01

Cat No.	Code No.	Part name	Qty	Remark	SN of application
1-1					
1-2					
1-3	LH52---0104Z2	NUT, ADJUSTMENT	2		
1-4	K0320040201	PIN, SPRING M4-20	2		
1-5	LH52---0105Z2	ADJUSTER, KNIFE 50	2		
1-6	K5051010260	WASHER, C5191P 1-10-26	2		
1-7	LH52---0103Z2	MOUNT	2		
1-8	LH52---0106Z8	SPRING, ALIGNING CUTTING EDGE	2		
1-9	K5000060002	WASHER, M6	2		
1-10	K0200060002	WASHER, SPRING M6	2		
1-11	K0000060102	BOLT, M6-10	2		
1-12	K5000140002	WASHER, M14	2		
1-13	K1000000458	SPRING, COMPRESSION M5-25-60	2		
1-14	LH52---0102Z2	SHAFT, ADJUSING BLADES	2		
1-15	K5012308262	WASHER, SPCC 2.3-8-26	2		
1-16	K0102080002	NUT, M8-3	2		
1-17	K1602080000	JOINT, SPHERICAL POS8	2		
1-18	K5000080002	WASHER, M8	2		
1-19	K0200080002	WASHER, SPRING M8	2		
1-20	K0000080302	BOLT, M8-30	2		
1-21	LH52---0110B0	FRAME ASSY, MOWER	1		
1-22	LH52---0101BR	FRAME	1		

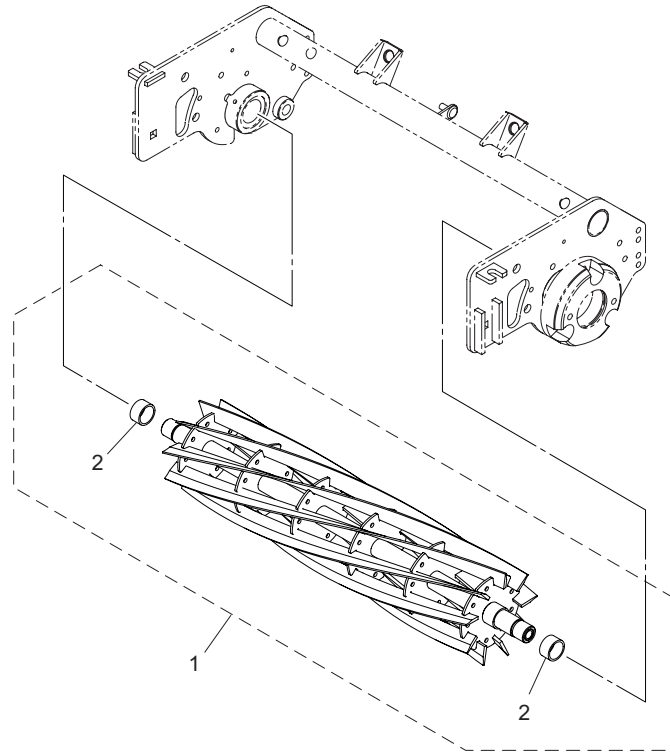

LH52_002_z00

Cat No.	Code No.	Part name	Qty	Remark	SN of application
2-1	LH529--0201A0	REEL CUTTER ASSY	1	9-blade	
2a-1	LH527--0201A0	REEL CUTTER ASSY	1	7-blade	
2b-1	LH521--0201A0	REEL CUTTER ASSY	1	11-blade	
2-2	K0737000100	INNER RACE, LRTZ253016	2		

3. Bed knife section

LH52

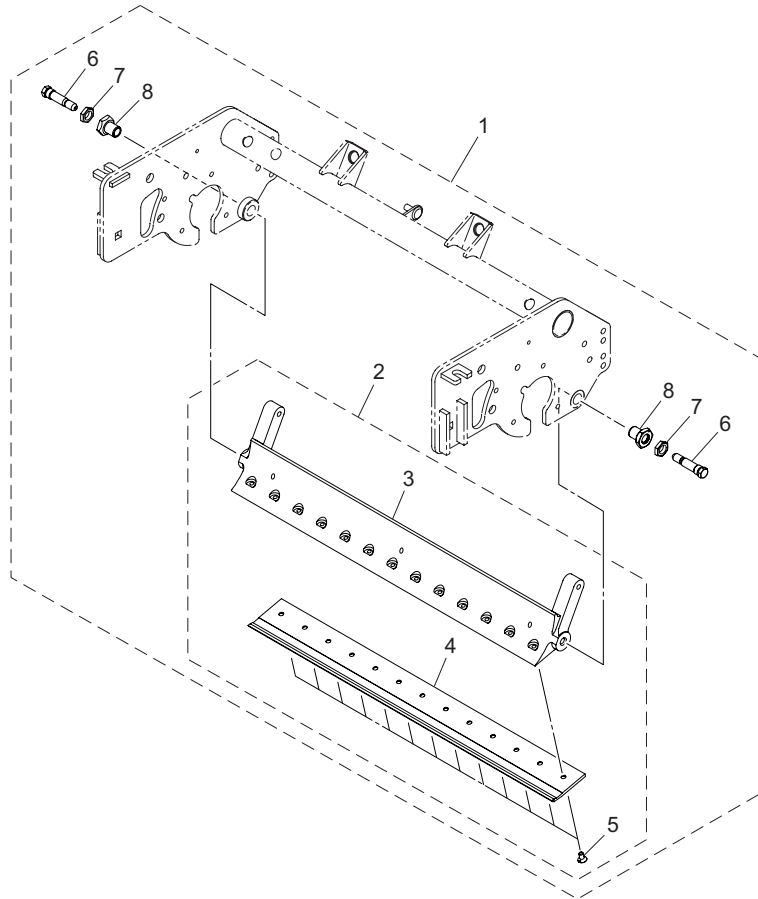

LH52_003_z00

Cat No.	Code No.	Part name	Qty	Remark	SN of application
3-1	LH52---1310A0	BEDKNIFE ASSY	1		
3-2	LH52---1302A0	BEDKNIFE & BASE ASSY	1		
3-3	LH52---1301AR	BASE, BED KNIFE	1		
3-4	K2510000160	BEDKNIFE, TIPPED 5.0-62.5-559	1		
3-5	K0071000222	SCREW, HT + FLAT HEAD M6-12	13		
3-6	K6082000010	BOLT, SUS STEPPED FOR FIXING CUTTER	2		
3-7	K0160000112	NUT, LOCKING	2		
3-8	K6010000010	BUSH, STEPPED	2		

4.Front roller section

LH52

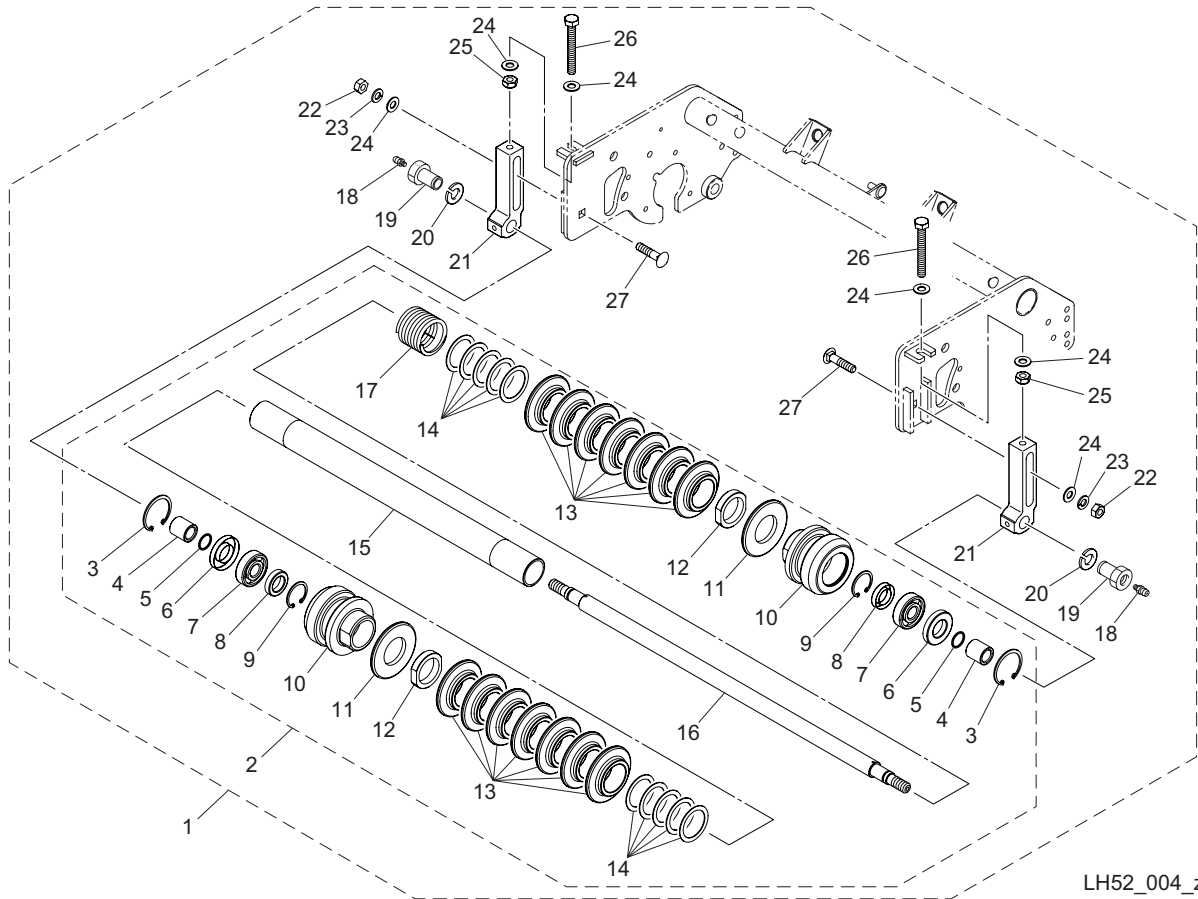

LH52_004_z00

Cat No.	Code No.	Part name	Qty	Remark	SN of application
4-1	LH52---0610A0	ROLLER ASSY, FRONT	1		
4-2	LH52---0603A0	ROLLER ASSY, 22	1		
4-3	K0402047001	RING, RETAINING R M47	2		
4-4	K6219000600	COLLAR, SUS M17-25-27	2		
4-5	K0885015000	O-RING, S15	2		
4-6	K0822547080	OIL SEAL, MHA25478	2		
4-7	K0600063030	BEARING, BALL 6303	2		
4-8	K0822235080	OIL SEAL, MHA22358	2		
4-9	K0402035001	RING, RETAINING R M35	2		
4-10	LH6690-0601AD	HOUSING, ROLLER	2		
4-11	K510100061D	PLATE, ROUND 80	2		
4-12	K016000062D	NUT, M40	2		
4-13	K5920000120	ROLLER, PLASTIC 80	14		
4-14	K5011040522	WASHER, SPCC 1-40-52	10		
4-15	LM2700-2109Z2	PIPE, ROLLER 34.2-40504.7	1		
4-16	LM2700-2107Z0	SHAFT, ROLLER 646.5	1		
4-17	K100000073D	SPRING, COMPRESSION M5-51-75	1		
4-18	K1440000010	GREASE NIPPLE, STRAIGHT TYPE A	2		
4-19	LH52---0602Z2	NUT	2		
4-20	K0200180002	WASHER, SPRING M18	2		
4-21	LH52---0601Z2	BRACKET, FRONT ROLLER	2		
4-22	K0100100002	NUT, M10	2		
4-23	K0200100002	WASHER, SPRING M10	2		
4-24	K5000100002	WASHER, M10	6		
4-25	K0144100002	NUT, W/F-RING M10	2		
4-26	K0000100802	BOLT, M10-80	2		
4-27	K0025100452	BOLT,CARRIAGE M10-45	2		

5.Rear roller section

LH52

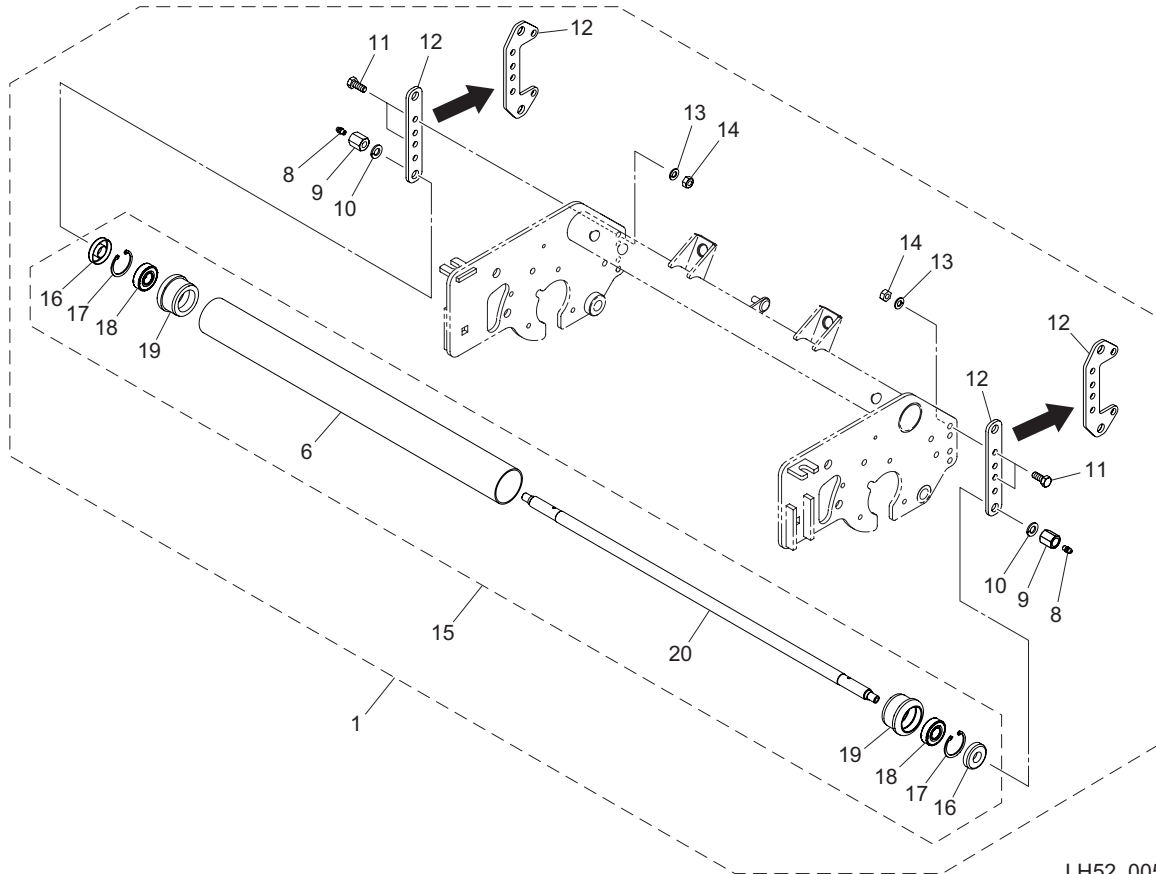

LH52_005_z03

Cat No.	Code No.	Part name	Qty	Remark	SN of application
5-1	LH52---0710A0	ROLLER ASSY, REAR	1		10136-10267
5a-1	LH52---0710B0	ROLLER ASSY, REAR	1		10268-
5-2					
5-3					
5-4					
5-5					
5-6	LM150GA1365AD	ROLLER, REAR	1		
5-7					
5-8	K1440000010	GREASE NIPPLE, STRAIGHT TYPE A	2		
5-9	LH52---0702Z2	NUT	2		
5-10	K0200100002	WASHER, SPRING M10	2		
5-11	K0010080202	BOLT, HT M8-20	4		
5-12	LH52---0701Z2	BRACKET, REAR ROLLER	2		10136-10267
5a-12	LH52---0705Z2	BRACKET, REAR ROLLER	2		10268-
5-13	K0200080002	WASHER, SPRING M8	4		
5-14	K0100080002	NUT, M8	4		
5-15	LH52---0711Z0	ROLLER ASSY	1		
5-16	K0851535080	OIL SEAL, PJN15358	2		
5-17	K0402035001	RING, RETAINING R M35	2		
5-18	K0612062020	BEARING, BALL SEAL 2RD 6202	2		
5-19	K6202000550	HOUSING, ROLLER	2		
5-20	LH52---0704Z0	SHAFT, ROLLER	1		

6.Housing section

LH52

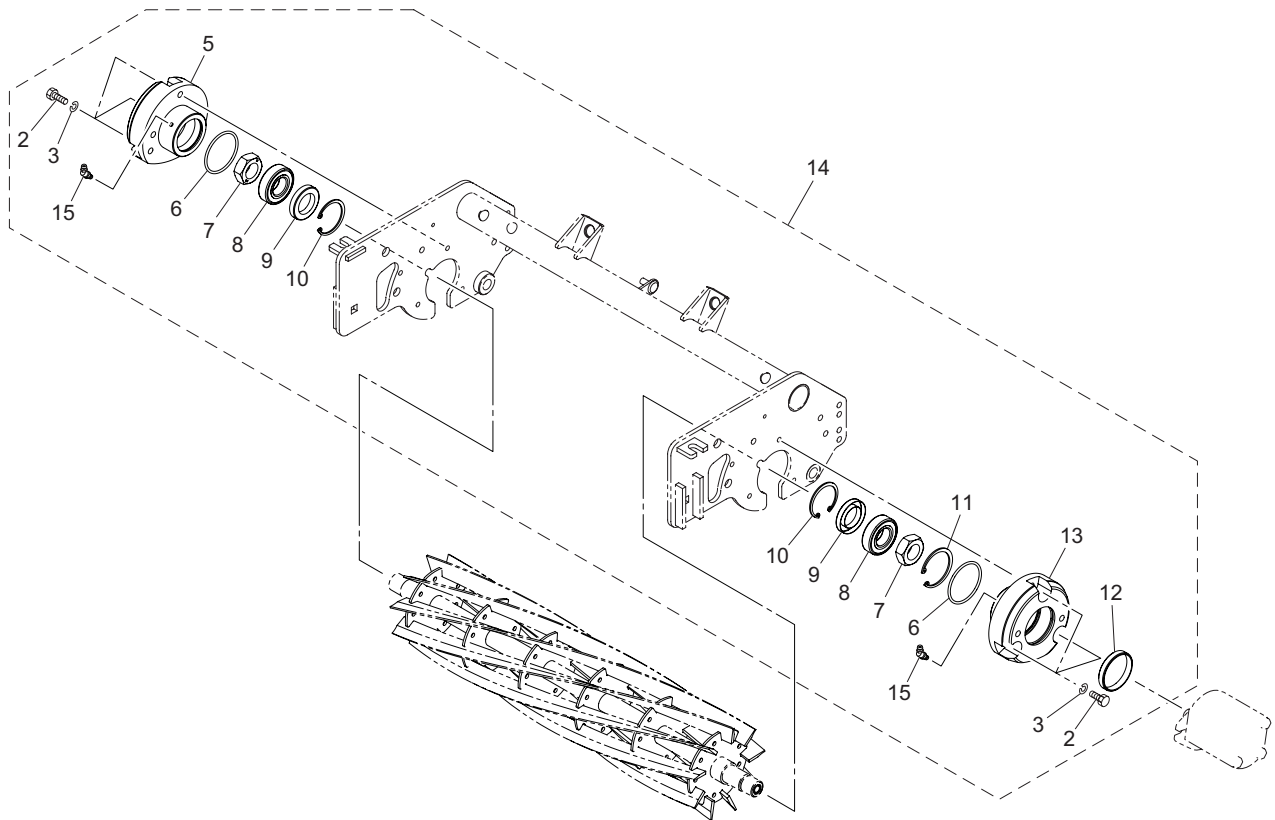

LH52_006_z01

Cat No.	Code No.	Part name	Qty	Remark	SN of application
6-1					
6-2	K0000080202	BOLT, M8-20	6		
6-3	K0200080002	WASHER, SPRING M8	6		
6-4					
6-5	LH52---0401Z2	HOUSING, REEL G	1		
6-6	K0882055000	O-RING, G55	2		
6-7	K0108240002	NUT, P1.5 M24-3	2		
6-8	K0606062050	BEARING, BALL SEAL RS 6205	2		
6-9	K0823047080	OIL SEAL, MHSA30478	2		
6-10	K0402047001	RING, RETAINING R M47	2		
6-11	K0402052001	RING, RETAINING R M52	1		
6-12	LH52---0403A2	COLLAR	1		
6-13	LH52---0402Z2	HOUSING, REEL M	1		
6-14	LH52---0410A0	HOUSING ASSY, REEL	1		
6-15	K1440000030	GREASE NIPPLE, 67.5 TYPE B	2		

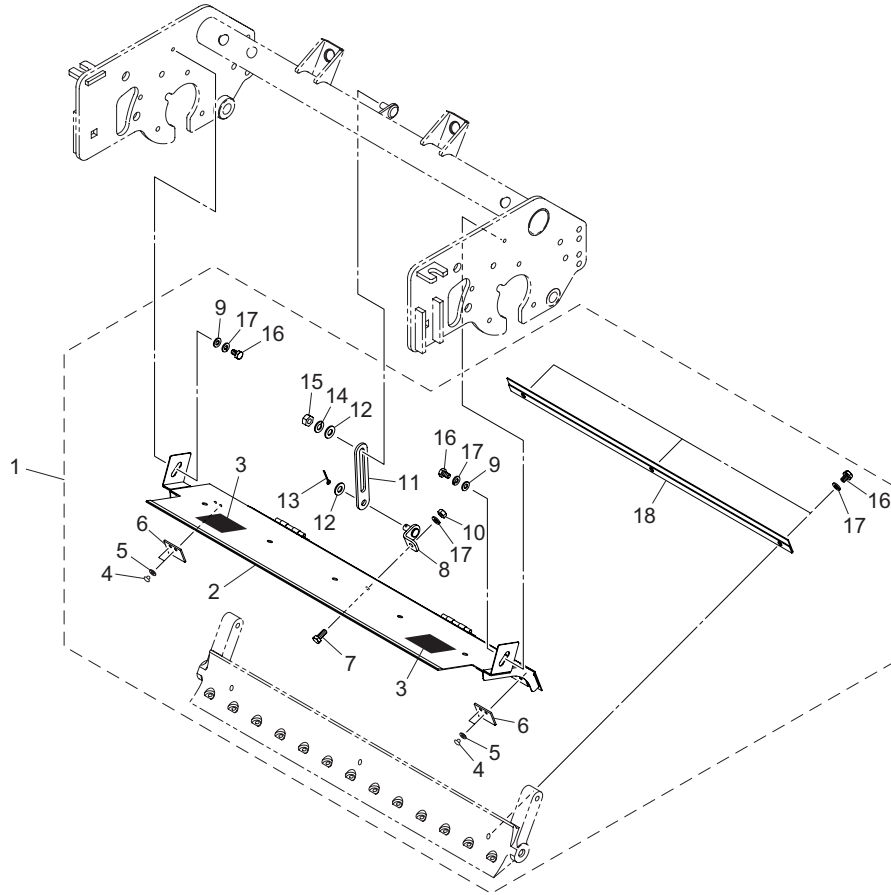

LH52_007_z00

Cat No.	Code No.	Part name	Qty	Remark	SN of application
7-1	LH52---2510Z0	COVER ASSY, REEL	1		
7-2	LH52---2511Z0	COVER COMP, REEL	1		
7-3	K4205001600	DECAL, CAUTION CUTTING HANDS/FEET	2		
7-4	K4510615120	RIVET, BLIND AVEX 1661-0512	4		
7-5	K5000050002	WASHER, M5	4		
7-6	LH52---2503Z0	RUBBER, PLATE	2		
7-7	K0000060152	BOLT, M6-15	1		
7-8	LH52---2502ZR	PLATE, MOUNTING	1		
7-9	K5000060002	WASHER, M6	2		
7-10	K0100060002	NUT, M6	1		
7-11	LH52---2504ZR	PLATE, STEEL	1		
7-12	K5000080002	WASHER, M8	2		
7-13	K0300025202	PIN, COTTER M2.5-20	1		
7-14	K0200080002	WASHER, SPRING M8	1		
7-15	K0100080002	NUT, M8	1		
7-16	K0000060102	BOLT, M6-10	5		
7-17	K0200060002	WASHER, SPRING M6	6		
7-18	LM56GB-0521ZR	CLAMPER, REEL COVER	1		

8.Groomer section A (motor on left side)

LH52

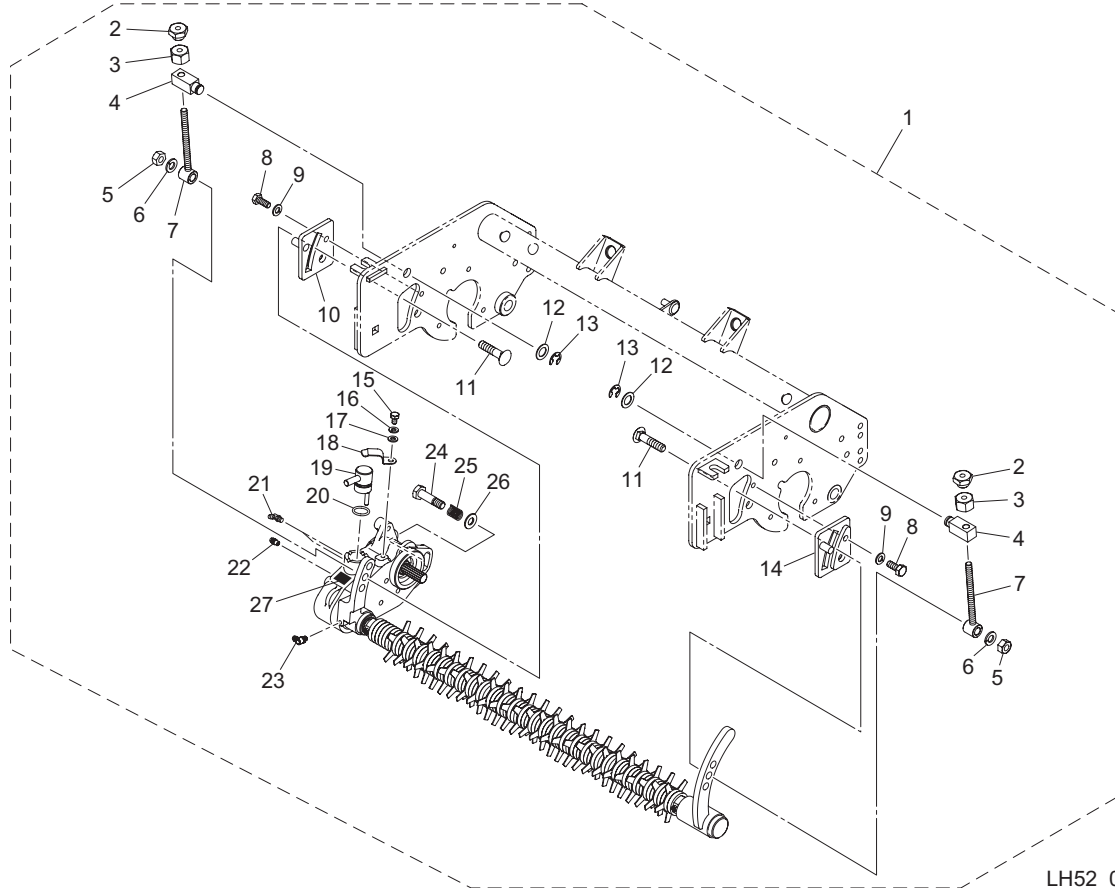

LH52_008_z00

Cat No.	Code No.	Part name	Qty	Remark	SN of application
8-1	LH52L--4121Z0	GROOMER & GEAR ASSY, (RH)	1	for Groomer	
8a-1	LH52L--4310Z0	GROOMER & GEAR ASSY, FOR CR MODEL (RH)	1	for Groomer + CR brush	
8-2	LM56G--1216Z2	NUT, SPECIAL B M8	2		
8-3	LM56G--1215Z2	NUT, SPECIAL A M8	2		
8-4	LH52L--4112Z2	ADJUSTER	2		
8-5	K0100100002	NUT, M10	2		
8-6	K0200100002	WASHER, SPRING M10	2		
8-7	LH52L--4113Z2	SCREW, ADJUSTING	2		
8-8	K0000080202	BOLT, M8-20	2		
8-9	K0200080002	WASHER, SPRING M8	2		
8-10	LH52L--4111ZR	GUIDE, (RH)	1		
8-11	K0025100452	BOLT,CARRIAGE M10-45	2		
8-12	K5011013222	WASHER, SPCC 1-13-22	2		
8-13	K0400010002	RING, RETAINING E M10	2		
8-14	LH52L--4110ZR	GUIDE, (LH)	1		
8-15	K0000060102	BOLT, M6-10	1		
8-16	K0200060002	WASHER, SPRING M6	1		
8-17	K5000060002	WASHER, M6	1		
8-18	K1090000058	SPRING, CLUTCH RETAINER	1		
8-19	LH52L--4107Z8	LEVER, CLUTCH (RH)	1		
8-20	K0880018000	O-RING, P18	1		
8-21	K1440000030	GREASE NIPPLE, 67.5 TYPE B	2		
8-22	K1440000010	GREASE NIPPLE, STRAIGHT TYPE A	1		
8-23	K1440000020	GREASE NIPPLE, 90 TYPE C	1		
8-24	LH52L--4108Z2	BOLT, SECURING CASE	1		
8-25	K1000000309	SPRING, COMPRESSION M1.6-13.7-20	1		
8-26	K5000100002	WASHER, M10	1		
8-27	K4203001120	LABEL, INDICATION GROOMER	1		

9.Groomer section B (motor on left side)

LH52

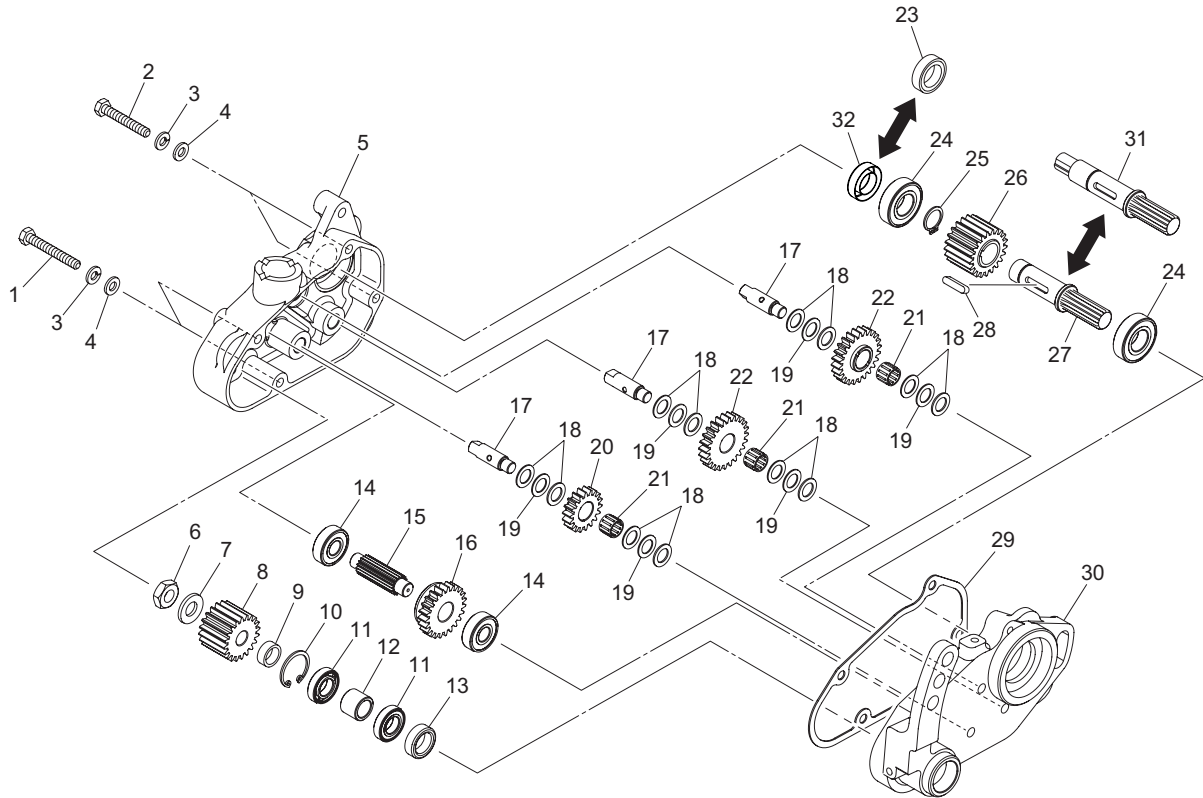

LH52_009_z00

Cat No.	Code No.	Part name	Qty	Remark	SN of application
9-1	K0000060452	BOLT, M6-45	2		
9-2	K0000060402	BOLT, M6-40	2		
9-3	K0200060002	WASHER, SPRING M6	4		
9-4	K5000060002	WASHER, M6	4		
9-5	LH52L--4102Z0	COVER, GEARCASE (RH)	1		
9-6	K0160000322	NUT, LEFT-HANDED P1 M10	1		
9-7	K0213100002	WASHER, DISK SPRING 1H M10	1		
9-8	K6180000160	GEAR, SPLINED 20-TEETH	1		
9-9	K6212001910	COLLAR, STKM M12.1-17-6	1		
9-10	K0402024001	RING, RETAINING R M24	1		
9-11	K0611069010	BEARING, BALL SEAL RDC3 6901	2		
9-12	K6212001590	COLLAR, STKM M12.1-17-14	1		
9-13	K0821522070	OIL SEAL, MHS15227	1		
9-14	K0608060000	BEARING, BALL SEAL 2RS 6000	2		
9-15	K6100000100	SHAFT, CLUTCH	1		
9-16	K6180000150	GEAR, SPLINED 23-TEETH	1		
9-17	K6120000310	COUNTERSHAFT, THREADED	3		
9-18	K5051010160	WASHER, C5191P 1-10-16	12		
9-19	K5020810160	WASHER, NBS55 0.8-10-16	6		
9-20	K6186000040	GEAR, 18-TEETH B	1		
9-21	K0701013100	BEARING, NEEDLE KT101310EGB2	3		
9-22	K6186000050	GEAR, 24-TEETH	2		
9-23	K0821525070	OIL SEAL, MHS15257	1	for Groomer + CR brush	
9-24	K0612060020	BEARING, BALL SEAL 2RD 6002	2		
9-25	K0401015001	RING, RETAINING S M15	1		
9-26	LH52L--4104Z0	GEAR, 21-TEETH	1		
9-27	LH52L--4101Z0	SHAFT, SPLINE	1	for Groomer	
9-28	K0500404180	KEY, BOTH ROUND M4-418	1		
9-29	LH52L--4105Z0	PACKING	1		
9-30	LH52L--4103Z0	CASE, GROOMER (RH)	1		

9.Groomer section B (motor on left side)

LH52

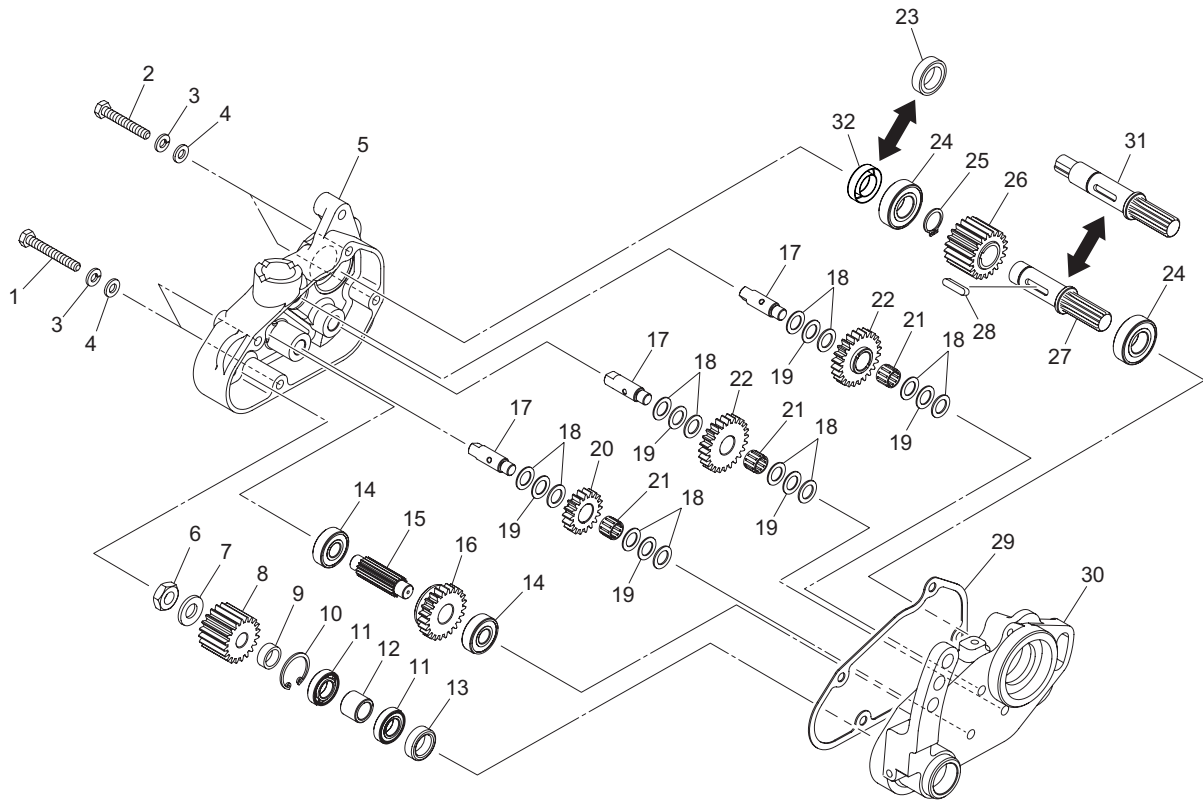

LH52_009_z00

Cat No.	Code No.	Part name	Qty	Remark	SN of application
9-31	LH52L--4205Z0	SHAFT, SPLINE	1	for Groomer + CR brush	
9-32	K0890000030	CAP, RUBBER 25	1	for Groomer	

10.Groomer section C (motor on left side)

LH52

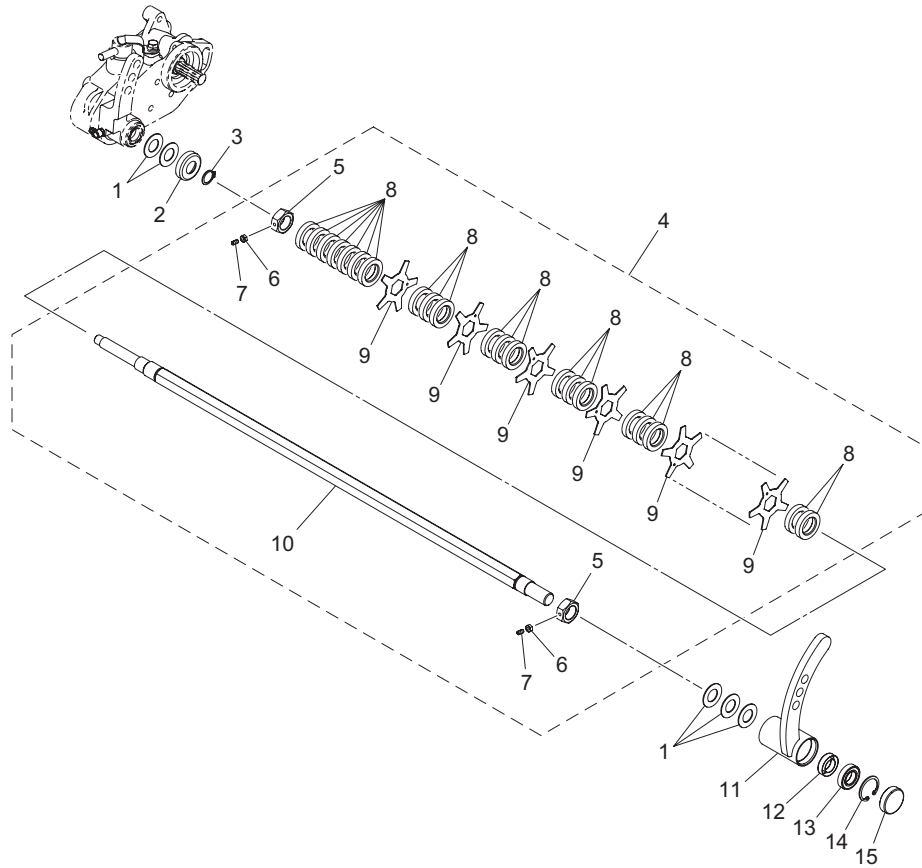

LH52_010_z01

Cat No.	Code No.	Part name	Qty	Remark	SN of application
10-1	K5051015280	WASHER, C5191P 1-15-28	5		
10-2	K5300000293	COVER, DUST PROOF	1		
10-3	K0401015001	RING, RETAINING S M15	1		
10-4	LH52L--4120Z0	GROOMER COMP	1		
10-5	K0160000602	NUT, SPECIAL P1 M17 W/M4	2		
10-6	K0100040002	NUT, M4	2		
10-7	K0023000041	SETSCREW, M4-8	2		
10-8	K6214000030	COLLAR, AC M19.7-32-6.1	87		
10-9	K2570000099	BLADE, VERTICAL 63-1	27		
10-10	LH52L--4109Z8	SHAFT, GROOMER	1		
10-11	LH52L--4106ZR	HOUSING, GROOMER (LH)	1		
10-12	K0821525070	OIL SEAL, MHSA15257	1		
10-13	K0608069020	BEARING, BALL SEAL 2RS 6902	1		
10-14	K0402028001	RING, RETAINING R M28	1		
10-15	K0890000060	CAP, RUBBER 30	1		

11.Groomer section D (motor on right side)

LH52

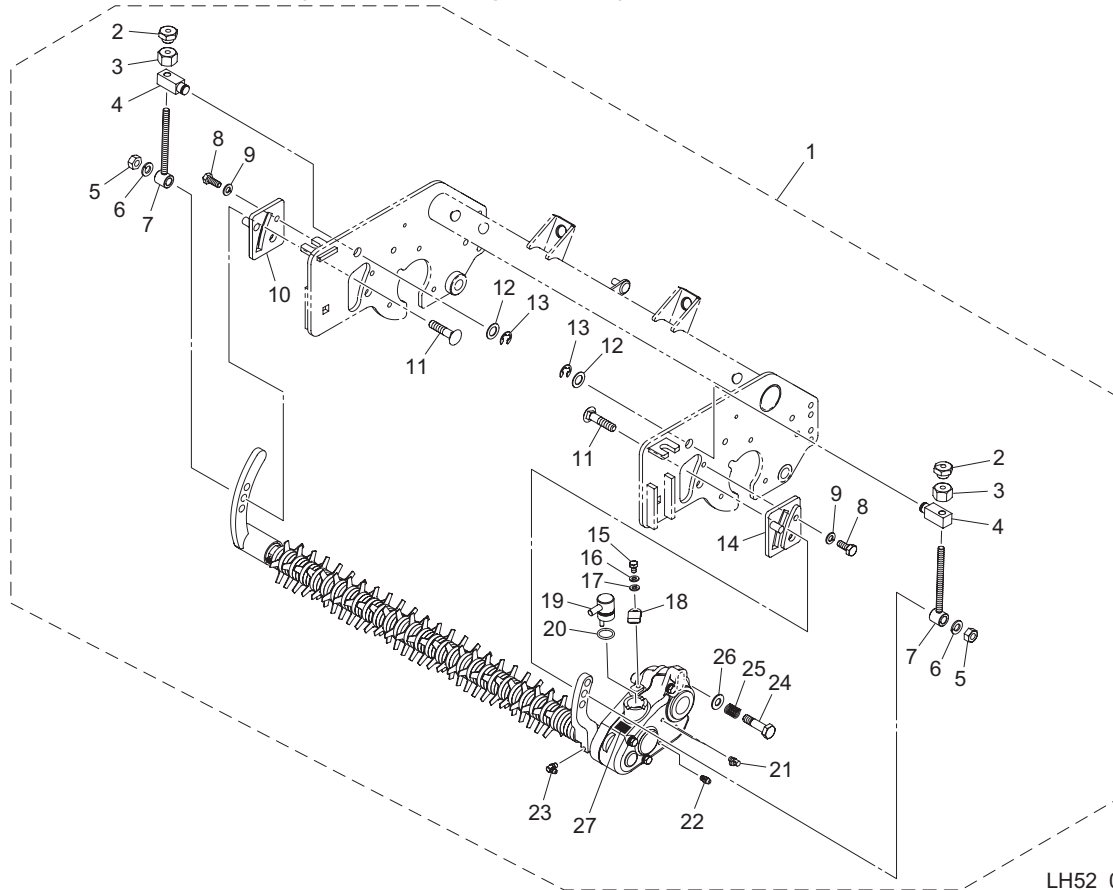

LH52_011_z00

Cat No.	Code No.	Part name	Qty	Remark	SN of application
11-1	LH52R--4110Z0	GROOMER & GEAR ASSY, (LH)	1	for Groomer	
11a-1	LH52R--4310Z0	GROOMER & GEAR ASSY, FOR CR MODEL (LH)	1	for Groomer + CR brush	
11-2	LM56G--1216Z2	NUT, SPECIAL B M8	2		
11-3	LM56G--1215Z2	NUT, SPECIAL A M8	2		
11-4	LH52L--4112Z2	ADJUSTER	2		
11-5	K0100100002	NUT, M10	2		
11-6	K0200100002	WASHER, SPRING M10	2		
11-7	LH52L--4113Z2	SCREW, ADJUSTING	2		
11-8	K0000080202	BOLT, M8-20	2		
11-9	K0200080002	WASHER, SPRING M8	2		
11-10	LH52L--4111ZR	GUIDE, (RH)	1		
11-11	K0025100452	BOLT,CARRIAGE M10-45	2		
11-12	K5011013222	WASHER, SPCC 1-13-22	2		
11-13	K0400010002	RING, RETAINING E M10	2		
11-14	LH52L--4110ZR	GUIDE, (LH)	1		
11-15	K0000060102	BOLT, M6-10	1		
11-16	K0200060002	WASHER, SPRING M6	1		
11-17	K5000060002	WASHER, M6	1		
11-18	K1090000058	SPRING, CLUTCH RETAINER	1		
11-19	LH52R--4104Z8	LEVER, CLUTCH (LH)	1		
11-20	K0880018000	O-RING, P18	1		
11-21	K1440000030	GREASE NIPPLE, 67.5 TYPE B	2		
11-22	K1440000010	GREASE NIPPLE, STRAIGHT TYPE A	1		
11-23	K1440000020	GREASE NIPPLE, 90 TYPE C	1		
11-24	LH52L--4108Z2	BOLT, SECURING CASE	1		
11-25	K1000000309	SPRING, COMPRESSION M1.6-13.7-20	1		
11-26	K5000100002	WASHER, M10	1		
11-27	K4203001680	LABEL, INDICATION GROOMER	1		

12.Groomer section E (motor on right side)

LH52

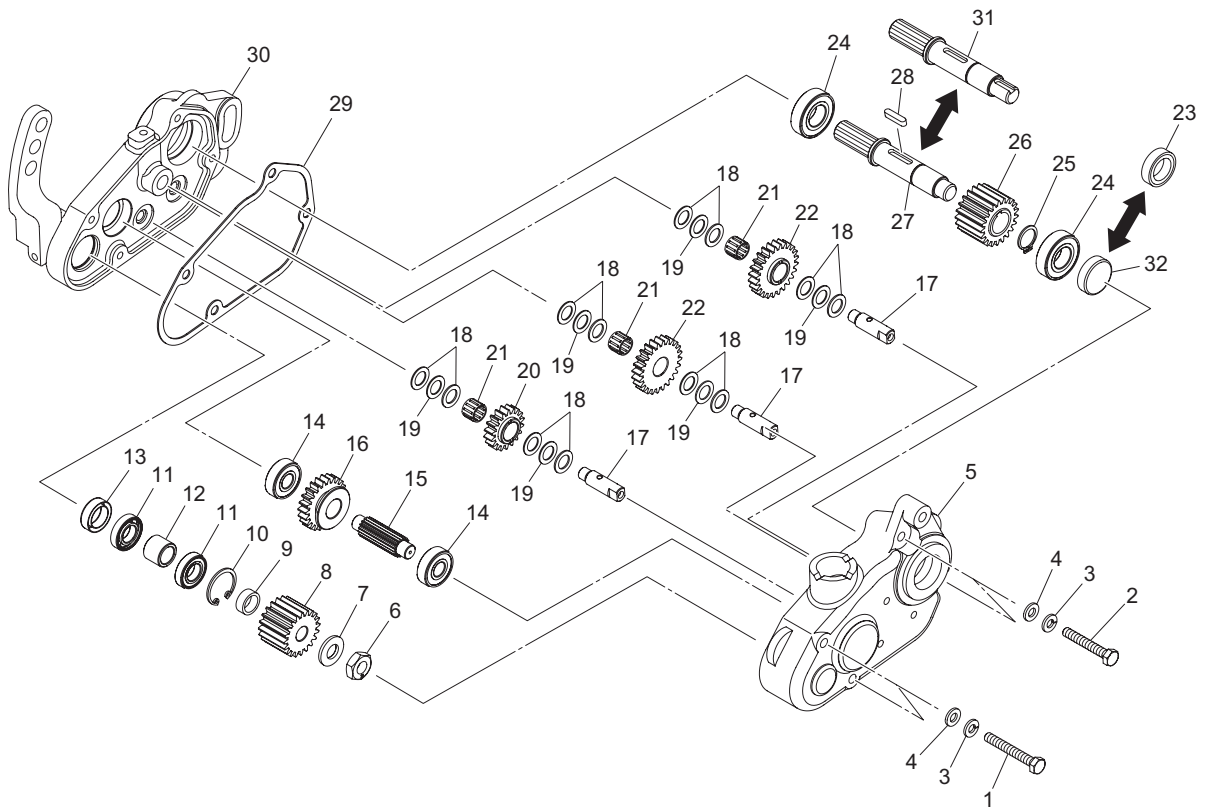

LH52_012_z00

Cat No.	Code No.	Part name	Qty	Remark	SN of application
12-1	K0000060452	BOLT, M6-45	2		
12-2	K0000060402	BOLT, M6-40	2		
12-3	K0200060002	WASHER, SPRING M6	4		
12-4	K5000060002	WASHER, M6	4		
12-5	LH52R--4101Z0	COVER, GEARCASE (LH)	1		
12-6	K0160000322	NUT, LEFT-HANDED P1 M10	1		
12-7	K0213100002	WASHER, DISK SPRING 1H M10	1		
12-8	K6180000160	GEAR, SPLINED 20-TEETH	1		
12-9	K6212001910	COLLAR, STKM M12.1-17-6	1		
12-10	K0402024001	RING, RETAINING R M24	1		
12-11	K0611069010	BEARING, BALL SEAL RDC3 6901	2		
12-12	K6212001590	COLLAR, STKM M12.1-17-14	1		
12-13	K0821522070	OIL SEAL, MHSA15227	1		
12-14	K0608060000	BEARING, BALL SEAL 2RS 6000	2		
12-15	K6100000100	SHAFT, CLUTCH	1		
12-16	K6180000150	GEAR, SPLINED 23-TEETH	1		
12-17	K6120000310	COUNTERSHAFT, THREADED	3		
12-18	K5051010160	WASHER, C5191P 1-10-16	12		
12-19	K5020810160	WASHER, NBS55 0.8-10-16	6		
12-20	K6186000040	GEAR, 18-TEETH B	1		
12-21	K0701013100	BEARING, NEEDLE KT101310EGB2	3		
12-22	K6186000050	GEAR, 24-TEETH	2		
12-23	K0821525070	OIL SEAL, MHSA15257	1	for Groomer + CR brush	
12-24	K0612060020	BEARING, BALL SEAL 2RD 6002	2		
12-25	K0401015001	RING, RETAINING S M15	1		
12-26	LH52L--4104Z0	GEAR, 21-TEETH	1		
12-27	LH52L--4101Z0	SHAFT, SPLINE	1	for Groomer	
12-28	K0500404180	KEY, BOTH ROUND M4-418	1		
12-29	LH52L--4105Z0	PACKING	1		
12-30	LH52R--4105Z0	CASE, GROOMER (LH)	1		

12.Groomer section E (motor on right side)

LH52

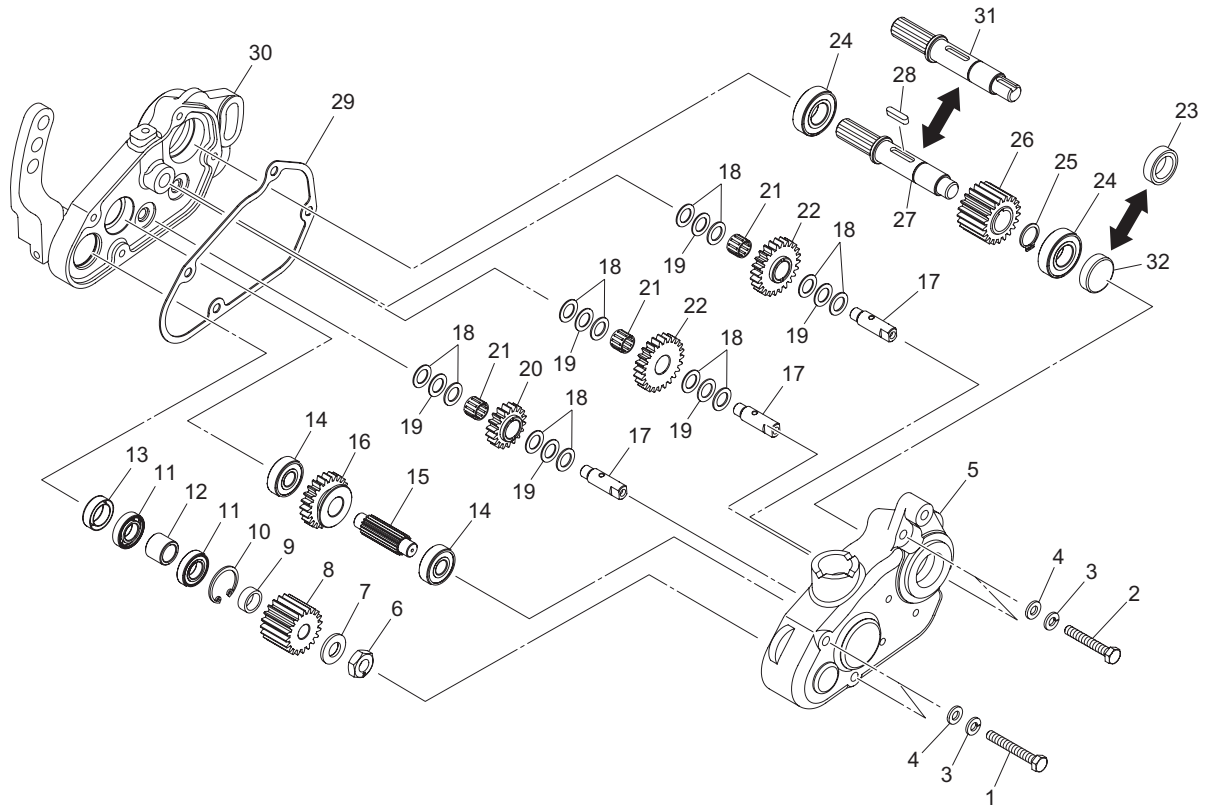

LH52_012_z00

Cat No.	Code No.	Part name	Qty	Remark	SN of application
12-31	LH52L--4205Z0	SHAFT, SPLINE	1	for Groomer + CR brush	
12-32	K0890000030	CAP, RUBBER 25	1	for Groomer	

13.Groomer section F (motor on right side)

LH52

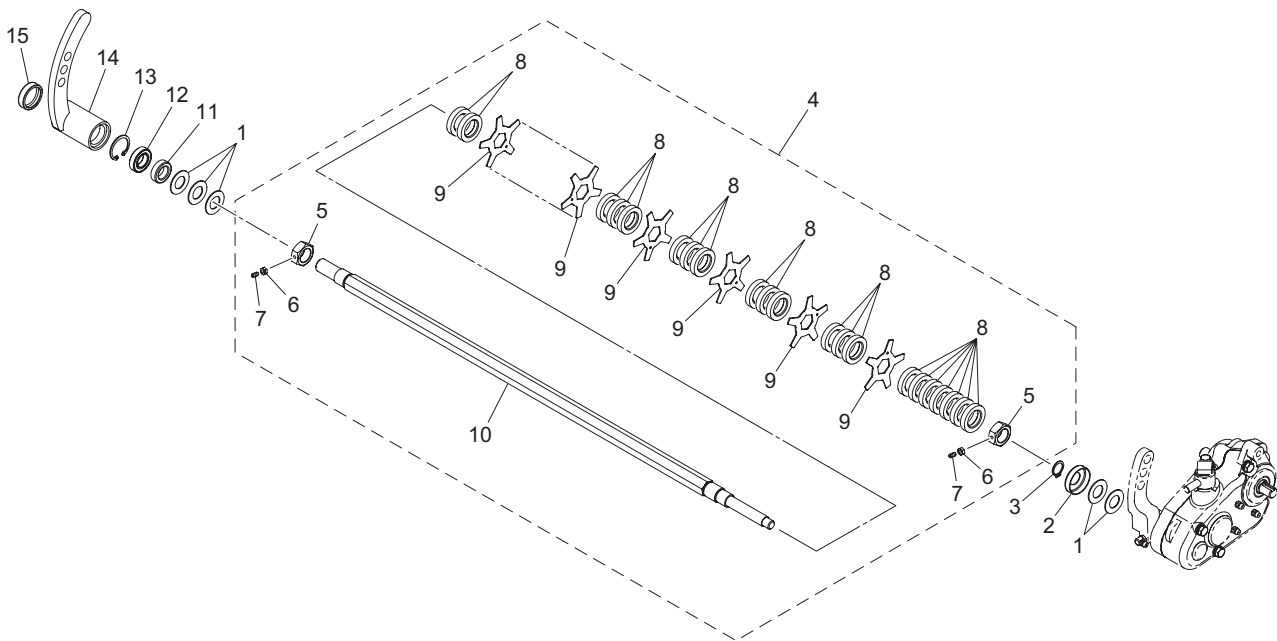

LH52_013_z01

Cat No.	Code No.	Part name	Qty	Remark	SN of application
13-1	K5051015280	WASHER, C5191P 1-15-28	5		
13-2	K5300000293	COVER, DUST PROOF	1		
13-3	K0401015001	RING, RETAINING S M15	1		
13-4	LH52L--4120Z0	GROOMER COMP	1		
13-5	K0160000602	NUT, SPECIAL P1 M17 W/M4	2		
13-6	K0100040002	NUT, M4	2		
13-7	K0023000041	SETSCREW, M4-8	2		
13-8	K6214000030	COLLAR, AC M19.7-32-6.1	87		
13-9	K2570000099	BLADE, VERTICAL 63-1	27		
13-10	LH52L--4109Z8	SHAFT, GROOMER	1		
13-11	K0821525070	OIL SEAL, MHSA15257	1		
13-12	K0608069020	BEARING, BALL SEAL 2RS 6902	1		
13-13	K0402028001	RING, RETAINING R M28	1		
13-14	LH52R--4103ZR	HOUSING, GROOMER (RH)	1		
13-15	K0890000060	CAP, RUBBER 30	1		

14.CR brush section A (motor on left side, right side)

LH52

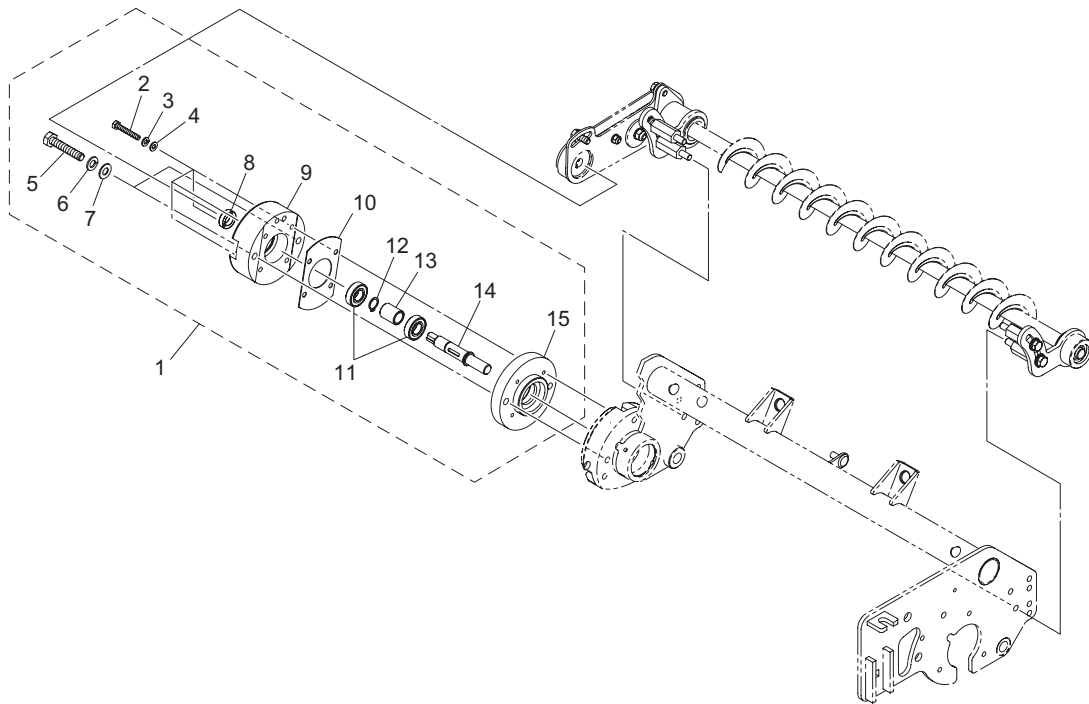

LH52_014_z00

Cat No.	Code No.	Part name	Qty	Remark	SN of application
14-1	LH52L--4221Z0	GEARCASE ASSY, CR LH52L	1		
14-2	K0000060402	BOLT, M6-40	4		
14-3	K0200060002	WASHER, SPRING M6	4		
14-4	K5000060002	WASHER, M6	4		
14-5	K0000100552	BOLT, M10-55	2		
14-6	K0200100002	WASHER, SPRING M10	2		
14-7	K5000100002	WASHER, M10	2		
14-8	K0821525070	OIL SEAL, MHSA15257	1		
14-9	LH52L--4202A0	COVER, GEARCASE CR BRUSH	1		
14-10	LH52L--4204Z0	PACKING	1		
14-11	K0612060020	BEARING, BALL SEAL 2RD 6002	2		
14-12	K0401015001	RING, RETAINING S M15	1		
14-13	LH52L--4203Z0	COLLAR	1		
14-14	LH52L--4205Z0	SHAFT, SPLINE	1		
14-15	LH52L--4201A0	GEARCASE, CR BRUSH	1		

15.CR brush section B (motor on left side)

LH52

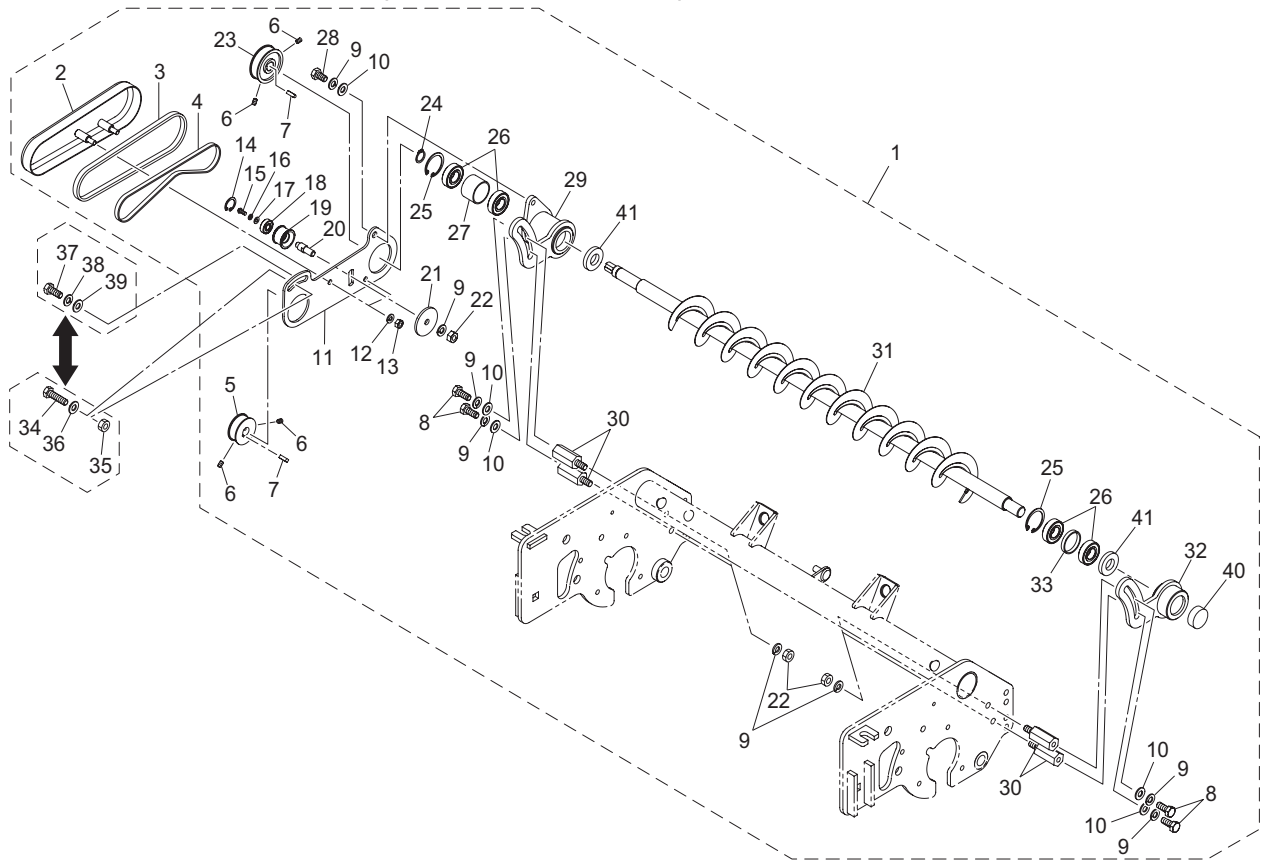

LH52_015_z02

Cat No.	Code No.	Part name	Qty	Remark	SN of application
15-1	LH52L--4220Z0	BRUSH ASSY, CR (RH)	1		10136-10265
15a-1	LH52L--4220A0	BRUSH ASSY, CR (RH)	1		10266-
15-2	LH52L--4210ZD	COVER, BELT (RH)	1		
15-3	LH52L--4211Z0	RUBBER, U 8-482	1		
15-4	K2380000170	BELT, F STAR 10FL-450	1		
15-5	LM2700-4106Z2	PULLEY, DRIVING	1		10136-10265
15a-5	LM2700-4106A2	PULLEY, DRIVING	1		10266-
15-6	K0023050081	SETSCREW, M5-8	4		
15-7	K0520404140	KEY, ROUND/SQUARE, M4-414	2		
15-8	K0000080202	BOLT, M8-20	4		
15-9	K0200080002	WASHER, SPRING M8	10		
15-10	K5000080002	WASHER, M8	5		
15-11	LH52L--4209Z2	PLATE, MOUNTING BRUSH	1		
15-12	K0200060002	WASHER, SPRING M6	2		
15-13	K0100060002	NUT, M6	2		
15-14	K0402019001	RING, RETAINING R M19	1		
15-15	K0042040102	SCREW, + ROUND HEAD M4-10	1		
15-16	K0200040002	WASHER, SPRING M4	1		
15-17	K5000040002	WASHER, M4	1		
15-18	K0608006070	BEARING, BALL SEAL 2RS 607	1		
15-19	LM315GC7609Z2	PULLEY, TENSION 1423	1		
15-20	LH52L--4206Z2	SHAFT	1		
15-21	K5073208402	WASHER, SPHC 3.2-8-40	1		
15-22	K0100080002	NUT, M8	5		
15-23	LM2700-4107Z2	PULLEY, BRUSH SHAFT	1		10136-10265
15a-23	LM2700-4107A2	PULLEY, BRUSH SHAFT	1		10266-
15-24	K0401015001	RING, RETAINING S M15	1		
15-25	K0402032001	RING, RETAINING R M32	2		
15-26	K0612060020	BEARING, BALL SEAL 2RD 6002	4		
15-27	LH669L-1317Z2	COLLAR, STKM 28.6-31.8-22	1		

15.CR brush section B (motor on left side)

LH52

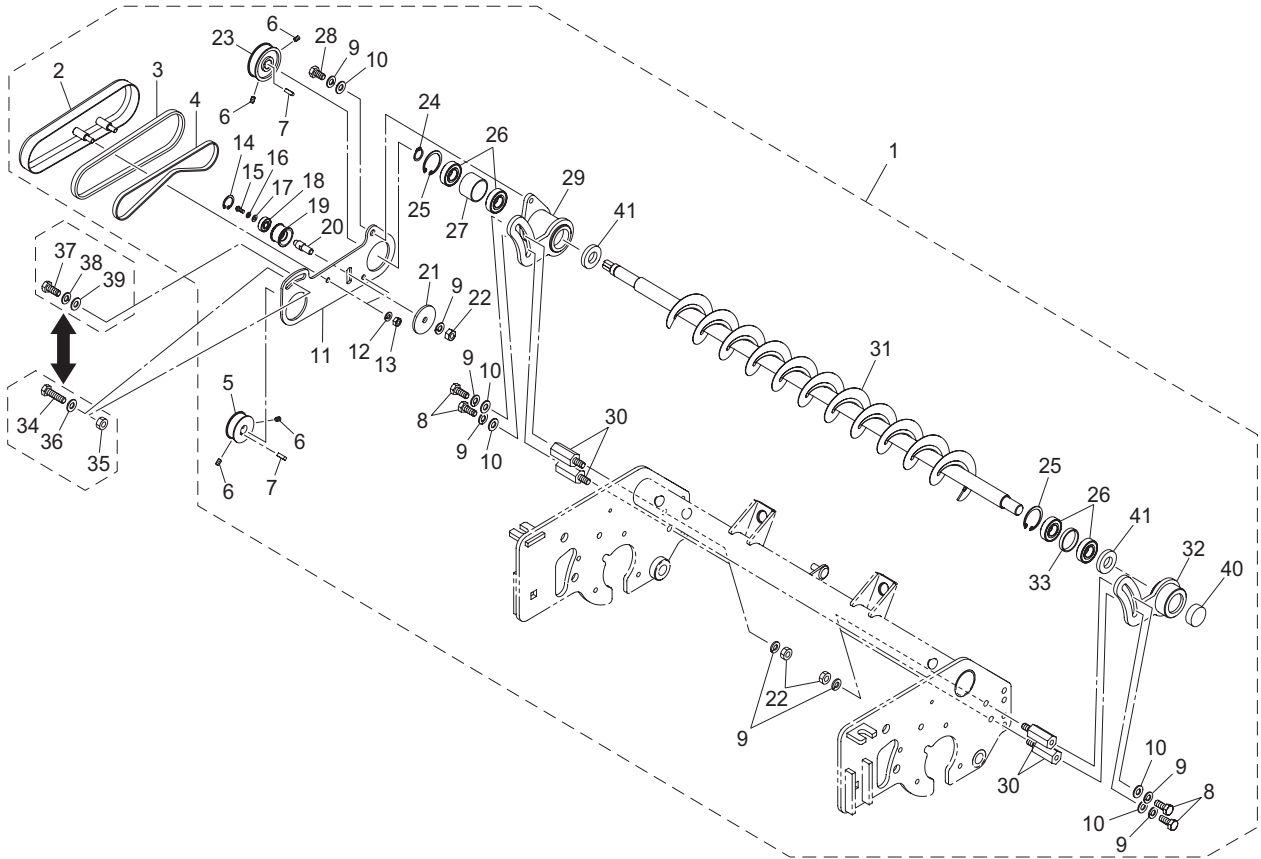

LH52_015_z02

Cat No.	Code No.	Part name	Qty	Remark	SN of application
15-28	K0000080152	BOLT, M8-15	1		
15-29	LH52L--4207ZD	HOUSING, BRUSH (RH)	1		10136-10367
15a-29	LH52L--4226ZD	HOUSING, BRUSH (RH)	1		10368-
15-30	LH52L--4214ZD	SHAFT	4	for Groomer + CR brush	
15-31	LH52L--4212A0	BRUSH, CR 22	1	for Groomer + CR brush	
15-32	LH52L--4208ZD	HOUSING, (LH)	1	for Groomer + CR brush	10136-10367
15a-32	LH52L--4227ZD	HOUSING, (LH)	1	for CR brush	10368-
15-33	K6212004172	COLLAR, STKM M28.6-31.8-5	1	for CR brush	
15-34	K0000080352	BOLT, M8-35	1	for CR brush	
15-35	K0144080002	NUT, W/F-RING M8	1		
15-36	K5000080002	WASHER, M8	1		
15-37	K0000080202	BOLT, M8-20	1		
15-38	K0200080002	WASHER, SPRING M8	1		
15-39	K5000080002	WASHER, M8	1		
15-40	K0890000050	CAP, RUBBER 28	1		
15-41	K0821932080	OIL SEAL, MHSA19328	2		10368-

16.CR brush section C (motor on right side)

LH52

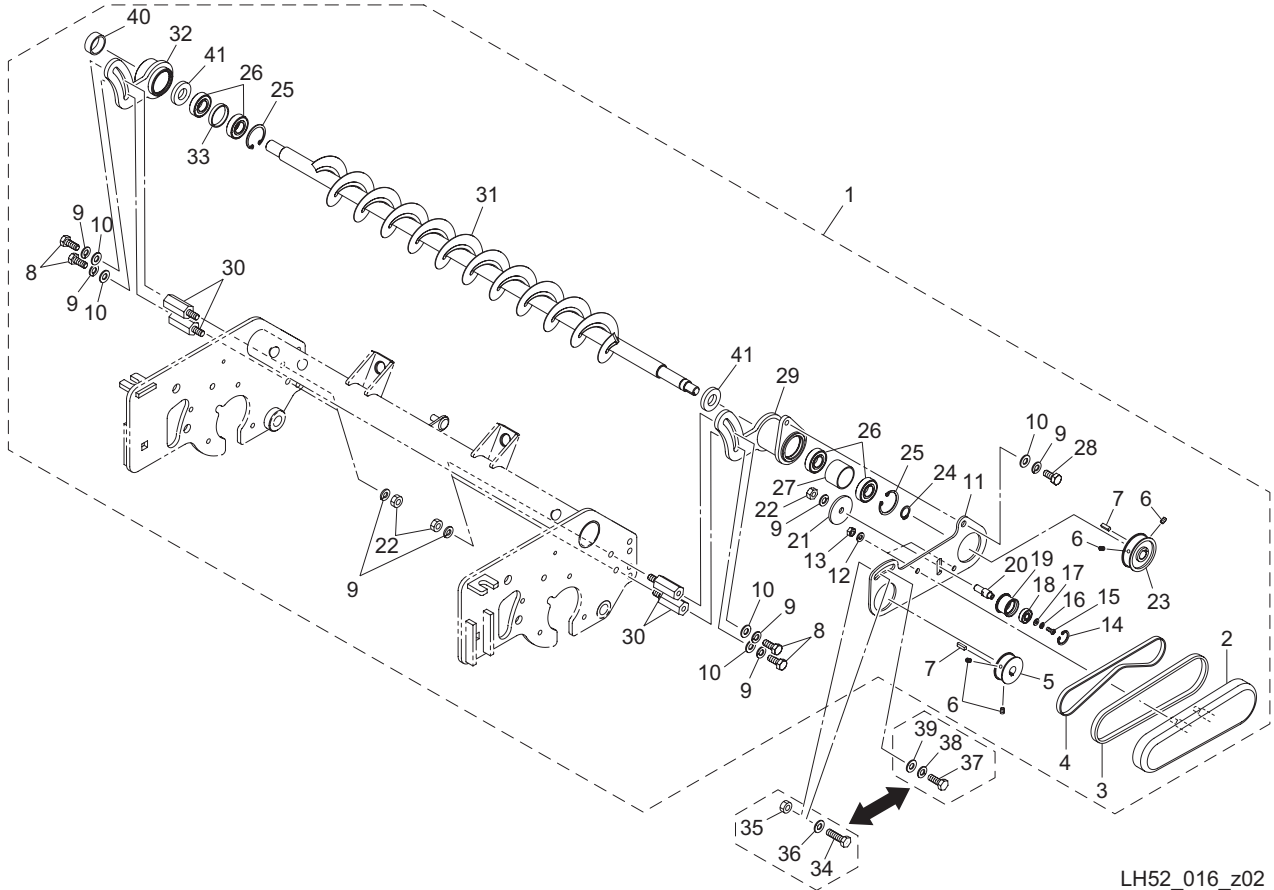

LH52_016_z02

Cat No.	Code No.	Part name	Qty	Remark	SN of application
16-1	LH52R--4220Z0	BRUSH ASSY, CR (LH)	1		10136-10265
16a-1	LH52R--4220A0	BRUSH ASSY, CR (LH)	1		10266-
16-2	LH52R--4203ZD	COVER, BELT (LH)	1		
16-3	LH52L--4211Z0	RUBBER, U 8-482	1		
16-4	K2380000170	BELT, F STAR 10FL-450	1		
16-5	LM2700-4106Z2	PULLEY, DRIVING	1		10136-10265
16a-5	LM2700-4106A2	PULLEY, DRIVING	1		10266-
16-6	K0023050081	SETSCREW, M5-8	4		
16-7	K0520404140	KEY, ROUND/SQUARE, M4-414	2		
16-8	K0000080202	BOLT, M8-20	4		
16-9	K0200080002	WASHER, SPRING M8	10		
16-10	K5000080002	WASHER, M8	5		
16-11	LH52L--4209Z2	PLATE, MOUNTING BRUSH	1		
16-12	K0200060002	WASHER, SPRING M6	2		
16-13	K0100060002	NUT, M6	2		
16-14	K0402019001	RING, RETAINING R M19	1		
16-15	K0042040102	SCREW, + ROUND HEAD M4-10	1		
16-16	K0200040002	WASHER, SPRING M4	1		
16-17	K5000040002	WASHER, M4	1		
16-18	K0608006070	BEARING, BALL SEAL 2RS 607	1		
16-19	LM315GC7609Z2	PULLEY, TENSION 1423	1		
16-20	LH52L--4206Z2	SHAFT	1		
16-21	K5073208402	WASHER, SPHC 3.2-8-40	1		
16-22	K0100080002	NUT, M8	5		
16-23	LM2700-4107Z2	PULLEY, BRUSH SHAFT	1		10136-10265
16a-23	LM2700-4107A2	PULLEY, BRUSH SHAFT	1		10266-
16-24	K0401015001	RING, RETAINING S M15	1		
16-25	K0402032001	RING, RETAINING R M32	2		
16-26	K0612060020	BEARING, BALL SEAL 2RD 6002	4		
16-27	LH669L-1317Z2	COLLAR, STKM 28.6-31.8-22	1		

16.CR brush section C (motor on right side)

LH52

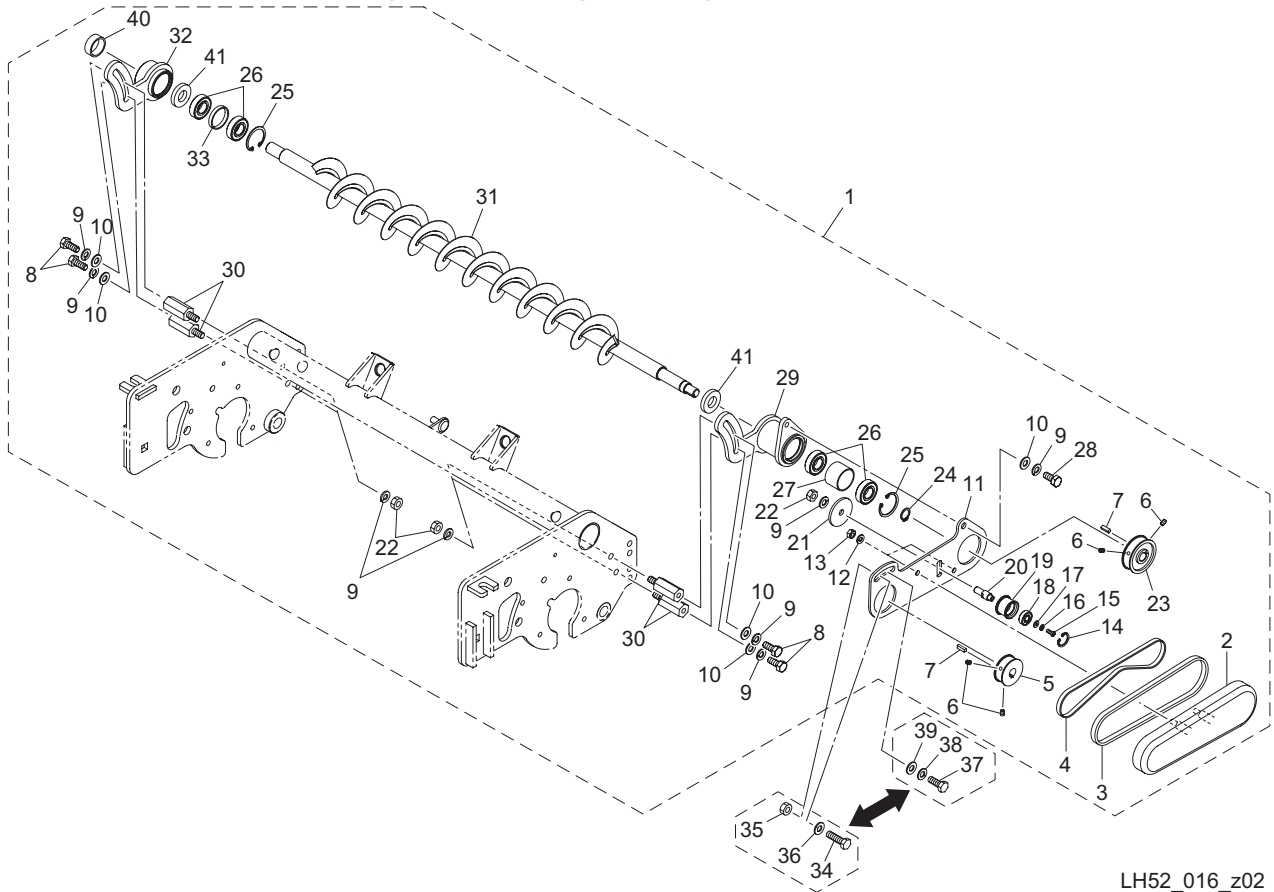

LH52_016_z02

Cat No.	Code No.	Part name	Qty	Remark	SN of application
16-28	K0000080152	BOLT, M8-15	1		
16-29	LH52R--4201ZD	HOUSING, BRUSH (LH)	1		10136-10367
16a-29	LH52R--4205ZD	HOUSING, BRUSH (LH)	1		10368-
16-30	LH52L--4214ZD	SHAFT	4	for Groomer + CR brush	
16-31	LH52L--4212A0	BRUSH, CR 22	1	for Groomer + CR brush	
16-32	LH52R--4202ZD	HOUSING, (RH)	1	for Groomer + CR brush	10136-10367
16a-32	LH52R--4206ZD	HOUSING, (RH)	1	for CR brush	10368-
16-33	K6212004172	COLLAR, STKM M28.6-31.8-5	1	for CR brush	
16-34	K0000080352	BOLT, M8-35	1	for CR brush	
16-35	K0144080002	NUT, W/F-RING M8	1		
16-36	K5000080002	WASHER, M8	1		
16-37	K0000080202	BOLT, M8-20	1		
16-38	K0200080002	WASHER, SPRING M8	1		
16-39	K5000080002	WASHER, M8	1		
16-40	K0890000050	CAP, RUBBER 28	1		
16-41	K0821932080	OIL SEAL, MHSA19328	2		10368-

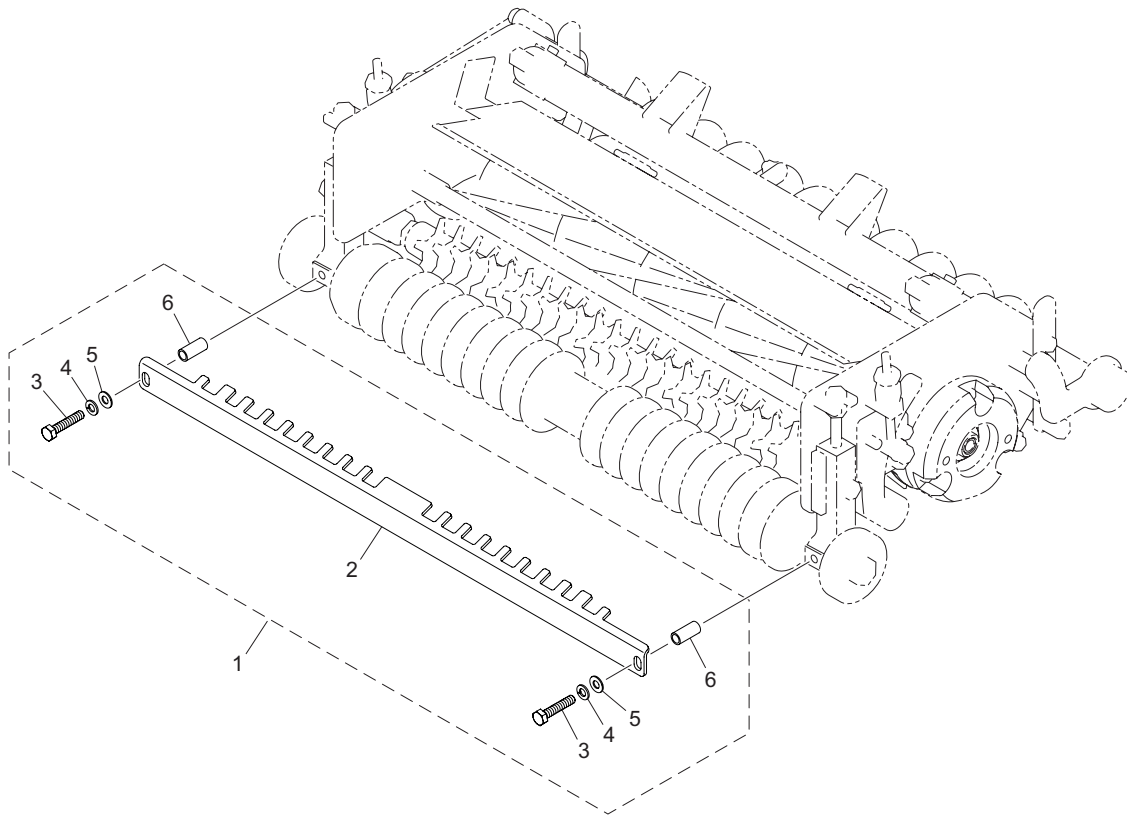

LH52_017_z00

Cat No.	Code No.	Part name	Qty	Remark	SN of application
17-1	LH52---4503Z0	SCRAPER ASSY	1		
17-2	LH52---4501ZD	SCRAPER, FRONT ROLLER	1		
17-3	K0000080402	BOLT, M8-40	2		
17-4	K0200080002	WASHER, SPRING M8	2		
17-5	K5000080002	WASHER, M8	2		
17-6	LH52---4502Z2	COLLAR, STKM 8.8-1226.5	2		

18.Rear scraper section

LH52

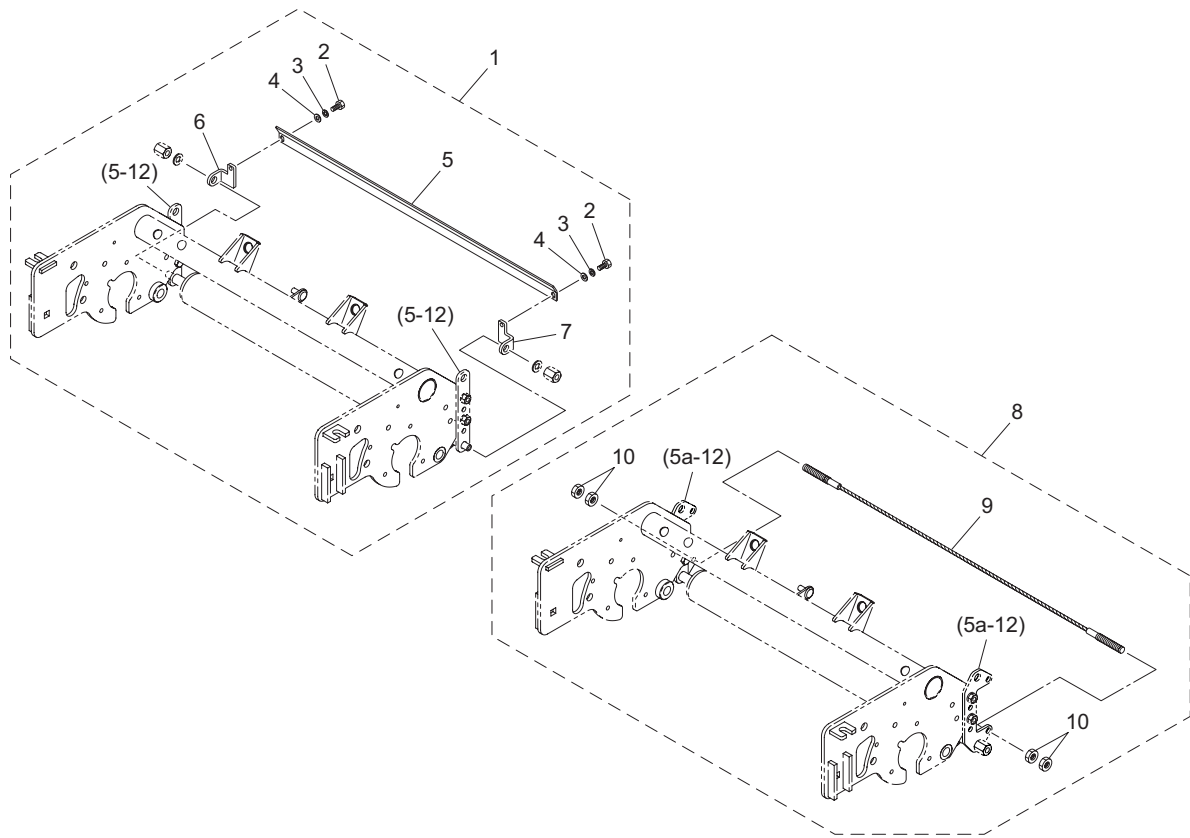

LH52_018_z01

Cat No.	Code No.	Part name	Qty	Remark	SN of application
18-1	LH52---4610Z0	SCRAPER ASSY	1		
18-2	K0000060102	BOLT, M6-10	2		
18-3	K0200060002	WASHER, SPRING M6	2		
18-4	K5000060002	WASHER, M6	2		
18-5	LH52---4601Z2	SCRAPER, REAR ROLLER	1		
18-6	LH52---4603Z2	BRACKET, REAR ROLLER SCRAPER (RH)	1		
18-7	LH52---4602Z2	BRACKET, REAR ROLLER SCRAPER (LH)	1		
18-8	LH52---4701Z0	SCRAPER ASSY, WIRE	1		
18-9	K1170067000	CABLE, 670	1		
18-10	K0100080002	NUT, M8	4		

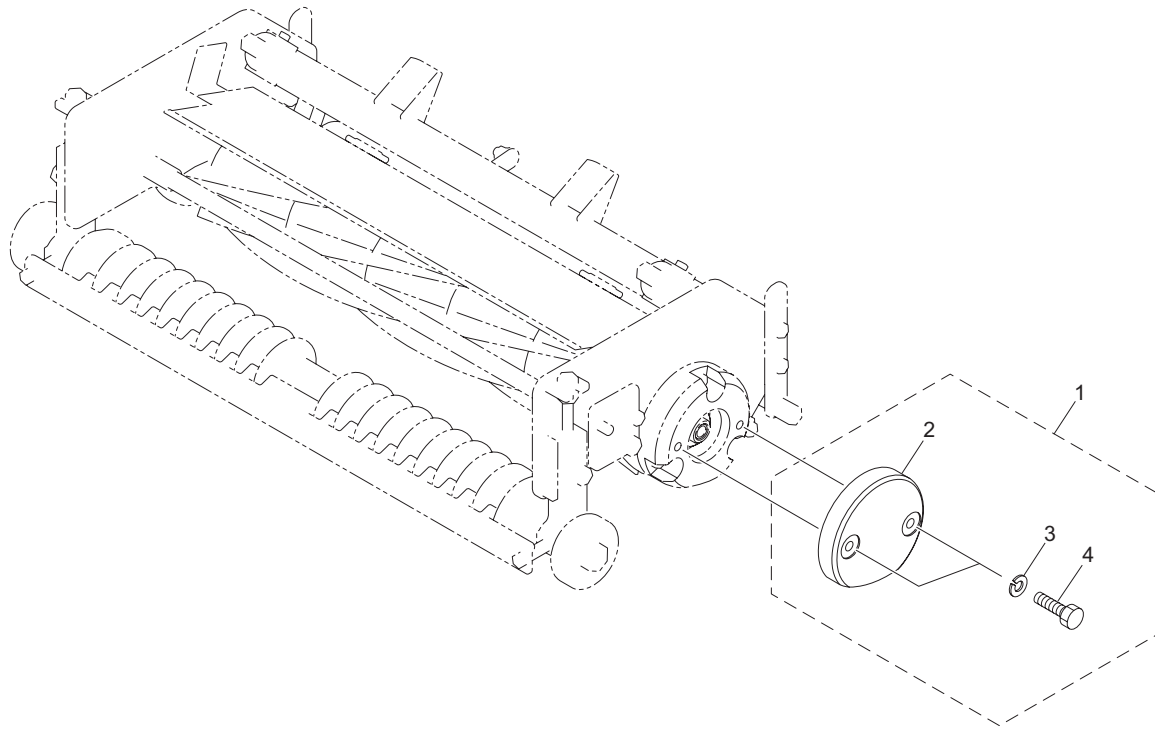

LH52_019_z00

Cat No.	Code No.	Part name	Qty	Remark	SN of application
19-1	LH52---0910Z0	WEIGHT ASSY, A	1		
19-2	LH52---0901ZR	WEIGHT, A	1		
19-3	K0200100002	WASHER, SPRING M10	2		
19-4	K0000100302	BOLT, M10-30	2		

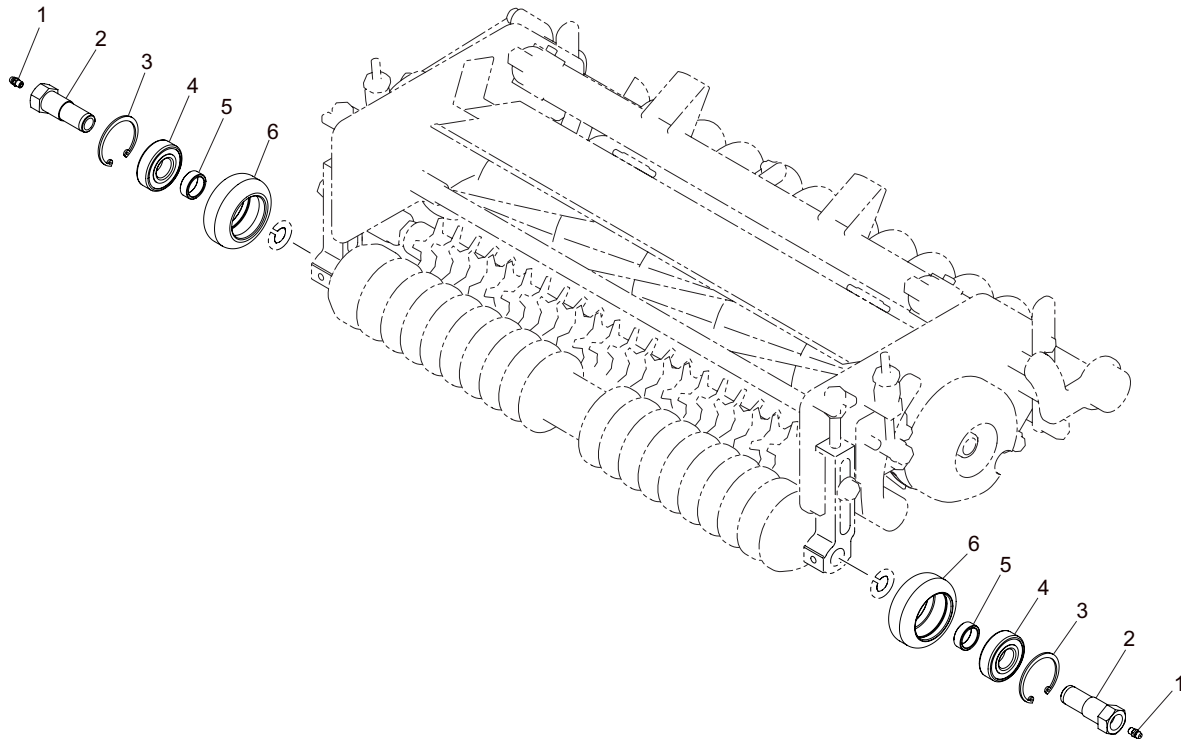

LH52_020_z00

Cat No.	Code No.	Part name	Qty	Remark	SN of application
20-1	K1440000010	GREASE NIPPLE, STRAIGHT TYPE A	2		
20-2	LH52---4801Z2	SHAFT, SUPPORT ROLLER	2		
20-3	K0402047001	RING, RETAINING R M47	2		
20-4	K0612062040	BEARING, BALL SEAL 2RD 6204	2		
20-5	LH52---4803Z2	COLLAR	2		
20-6	LH52---4802Z0	ROLLER, SUPPORT	2		

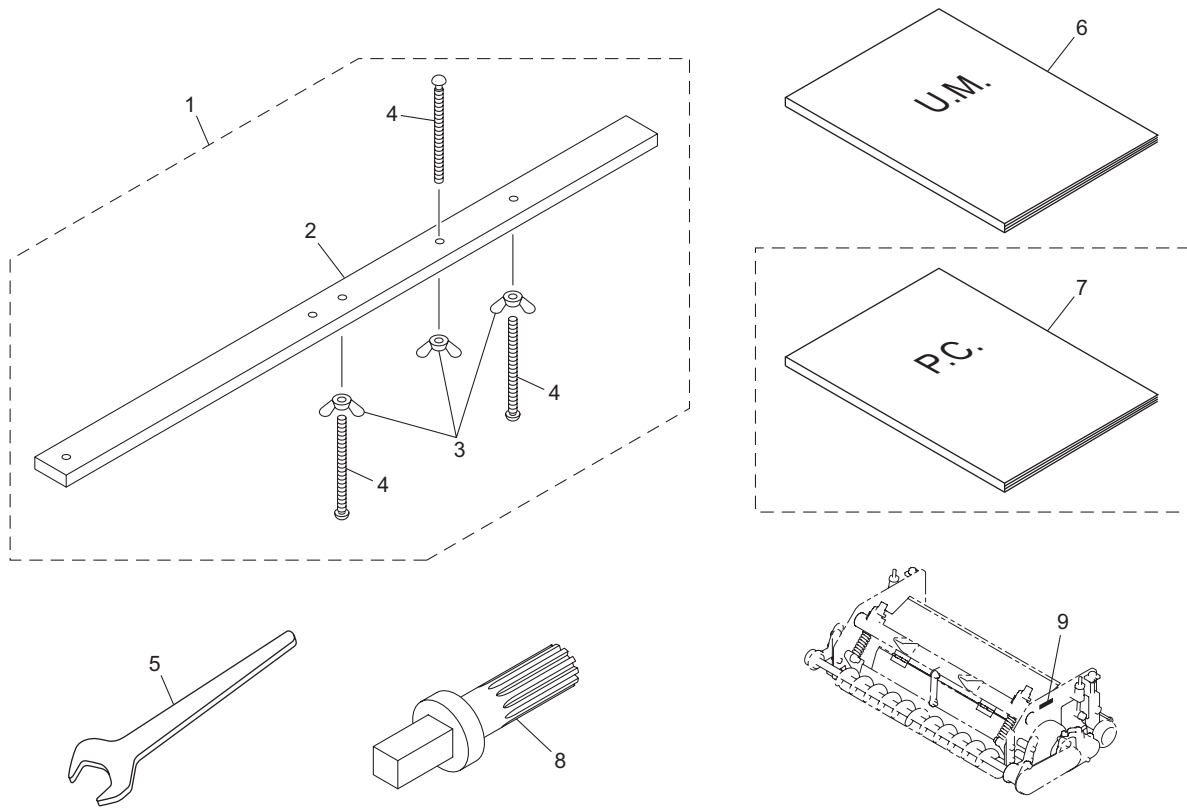

LH52_021_z04

Cat No.	Code No.	Part name	Qty	Remark	SN of application
21-1	LM2700-1502A0	GAUGE ASSY, CUTTING HEIGHT	1		
21-2	LM2700-1501A2	GAUGE, CUTTING HEIGHT 600A	1		
21-3	K0141060002	NUT, WING M6-3	3		
21-4	K0071000522	SCREW, FOR ADJ HOC M6-75	3		
21-5	K480200081D	SPANNER, SLIM SINGLE-ENDED 46	1		
21a-6	750101-142-A	OWNERS OPERATING MANUAL, LH52	1		
21a-7	750101-142-B	PARTS CATALOG, LH52	1	Available for sale	10266-
21-8	LH52---7001Z2	SHAFT, LAPPING	1	option	
21-9	LH52---0111Z0	LABEL, QR CODE LH52	1		10266-

BARONESS[®]
Quality on Demand

 **KYOEISHA CO., LTD.**
Head Office 1-26, Miyuki-cho, Toyokawa-city, Tel :+81-533-84-1390
Aichi-pref, 442-8530 JAPAN Fax :+81-533-84-1220